



## Codice d'ordine. Ordering example.

B40 – A1 – S4 – PL – A – 45 – A – A

### Modello / Type:

**B40** (spessore lamiera fisso)  
(fixed thickness)

alesaggio / cylinder bore 40 mm

**B40V** (spessore lamiera variabile)  
(variable thickness)

alesaggio / cylinder bore 40 mm

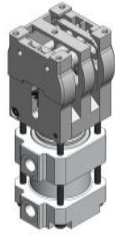

### Angolo d'apertura: Opening angle:

B40A	22,5°	45°	80°
B40B	45°	90°	160°
B40VA	22,5°	45°	80°
B40VB	45°	90°	160°

### Tipologia bracci e tasselli:

#### Type of arms and blocks:

**AX:** braccio singolo senza tassello  
single arm without block

**A1:** braccio singolo con tassello singolo  
single arm with single block

**A2:** braccio singolo con tassello doppio  
single arm with double block

**BX:** bracci doppi senza tasselli  
double arms without blocks

**B1:** bracci doppi con tasselli singoli  
double arms with single blocks

**B2:** bracci doppi con tasselli doppi  
double arms with double blocks

**N.B.:** per maggiori informazioni vedere le pagine dimensionali.

**NOTE:** for other information see dimensional pages.



### Tipologia finecorsa induttivo:

#### Type of proximity-switch:

**A:** finecorsa induttivo standard P+F  
standard proximity-switch P+F

**B:** finecorsa induttivo P+F con LED bianco (normativa Porsche)  
proximity-switch P+F with white LED (Porsche normative)

**N.B.:** per informazioni vedere pagina 11

**NOTE:** for other information see page 11.

### Tipologia perni di bloccaggio:

#### Type of lock-pins:

**X:** senza perno  
without pin

**A:** perni M8 con testa esagonale zigrinata  
pins M8 with hexagonal knurled head

**B:** perni M8 con testa bombata  
pins M8 with rounded head



### Rondella di spessoramento:

#### Thickness washer:

**SX:** senza rondella (usare sempre con bracci tipo "B")  
without washer (always for type "B" arms)

**S4:** rondella standard di spessore 4 mm;  
standard washer of 4 mm of thickness;

**N.B.:** possibilità di richiedere spessori da 1 a 6 mm inserendo S1, S2, S3, S4, S5, S6.

**NOTE:** possibility to demand a thickness washer from 1 mm to 6 mm putting S1, S2, S3, S4, S5, S6.



### Posizione finecorsa induttivo:

#### Inductive proximity-switch position:

**PX:** senza finecorsa  
without proximity-switch

**PL:** finecorsa P+F sul lato sinistro  
proximity-switch P+F on left side

**PR:** finecorsa P+F sul lato destro  
proximity-switch P+F on right side

**N.B.:** la posizione dei fori d'alimentazione segue sempre la posizione del finecorsa.

**NOTE:** the feeding ports position is always the same of proximity-switch one.

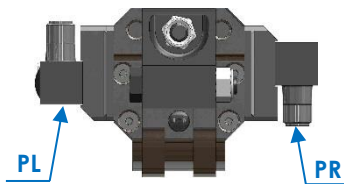

### Tipologia di attacco:

#### Type of fixing plates:

**A:** piastra di fissaggio standard  
standard fixing plate

**B30:** piastra di fissaggio con snodo Ø30 mm  
fixing plate with ball joint Ø30 mm

**B40:** piastra di fissaggio con snodo Ø40 mm  
fixing plate with ball joint Ø40 mm

**C:** piastra di fissaggio inferiore  
lower fixing plate





## B40-AX...

Gripper D. 40, braccio singolo, no pin, fissaggio standard  
 Gripper D. 40, single arm, no pin, standard fixing plate

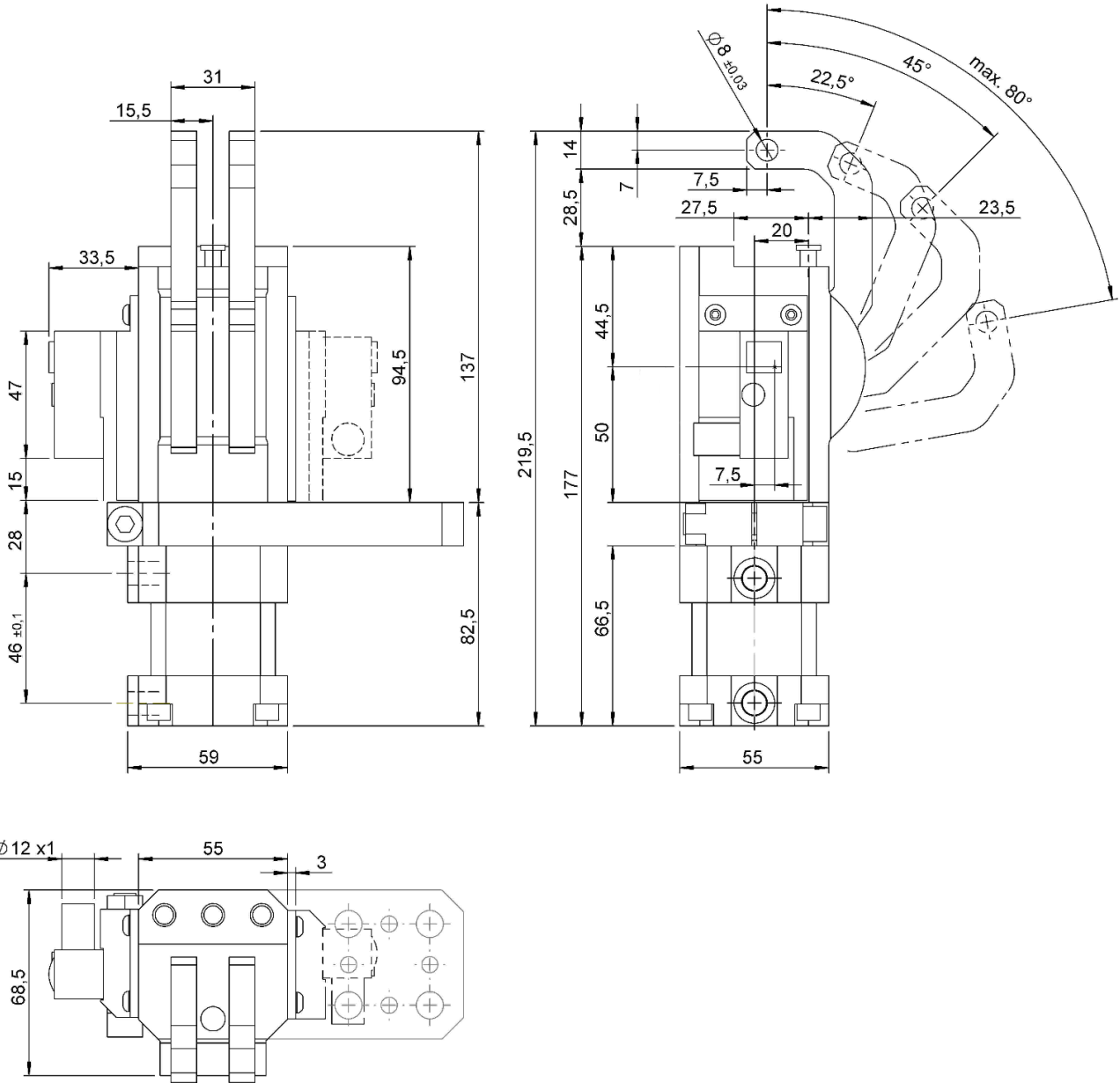

Modello Type	Alesaggio cilindro Cylinder bore	Compensazione spessore lamiera Metal sheet compensation	Forza di bloccaggio (5 bar) Clamping force (5 bar)	Peso Weight	Pressione di lavoro Working pressure	Angoli d'apertura Opening angle
	[ mm ]	[ mm ]	[ N ]	[ Kg ]	[ bar ]	[ ° ]
B40-AX...	40	0	1400	~ 2,5	4 - 8	22,5° - 45° - 80°
B40V-AX...		1,5	1050			



## B40-A1...

Gripper D. 40, braccio singolo, 1 pin, fissaggio standard  
Gripper D. 40, single arm, 1 pin, standard fixing plate

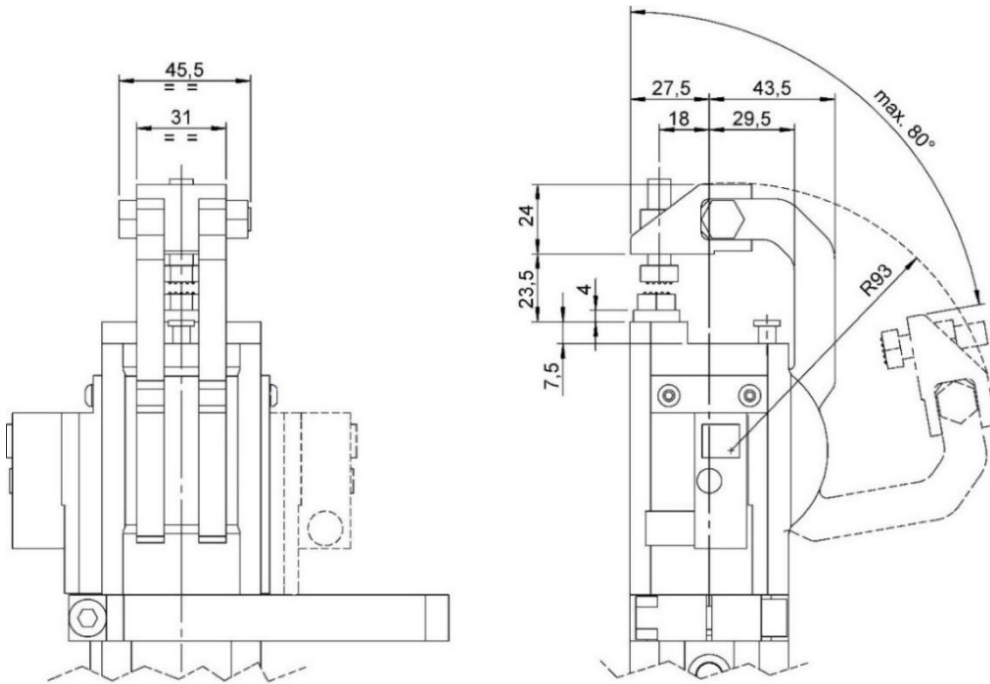

## B40-A2...

Gripper D. 40, braccio singolo, 2 pins, fissaggio standard  
Gripper D. 40, single arm, 2 pins, standard fixing plate

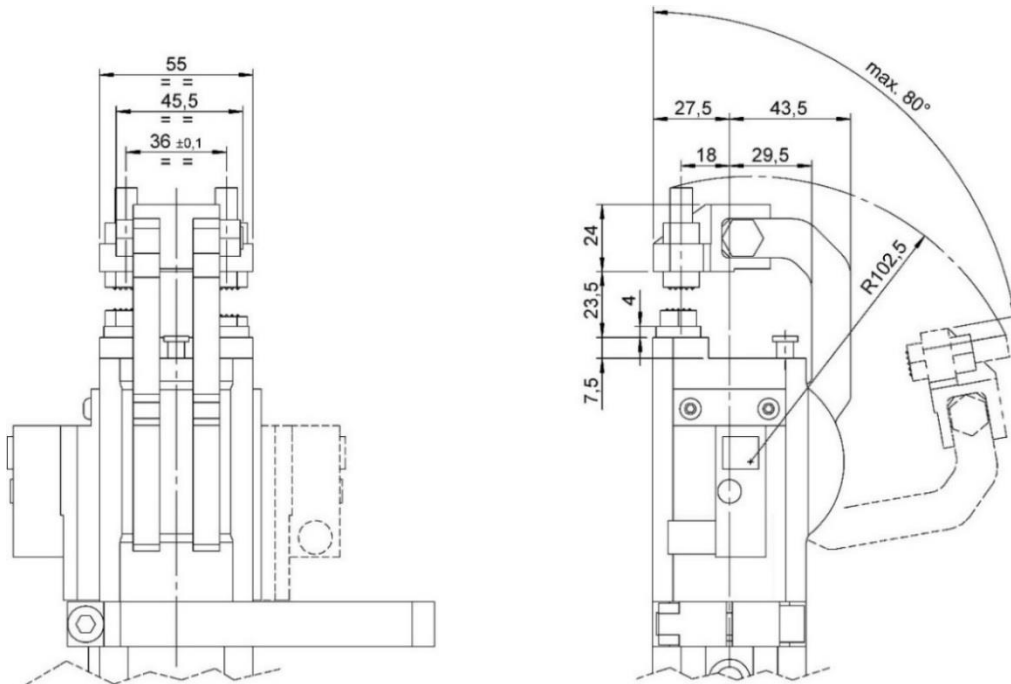

Modello Type	Alesaggio cilindro Cylinder bore	Compensazione spessore lamiera Metal sheet compensation	Forza di bloccaggio (5 bar) Clamping force (5 bar)	Peso Weight	Pressione di lavoro Working pressure	Angoli d'apertura Opening angle
	[ mm ]	[ mm ]	[ N ]	[ Kg ]	[ bar ]	[ ° ]
B40-A...	40	0	1400	~ 2,5	4 - 8	22,5° - 45° - 80°
B40V-A...		1,5	1050			



## B40-BX...

Gripper D. 40, braccio doppio, no pin, fissaggio standard  
 Gripper D. 40, double arm, no pin, standard fixing plate

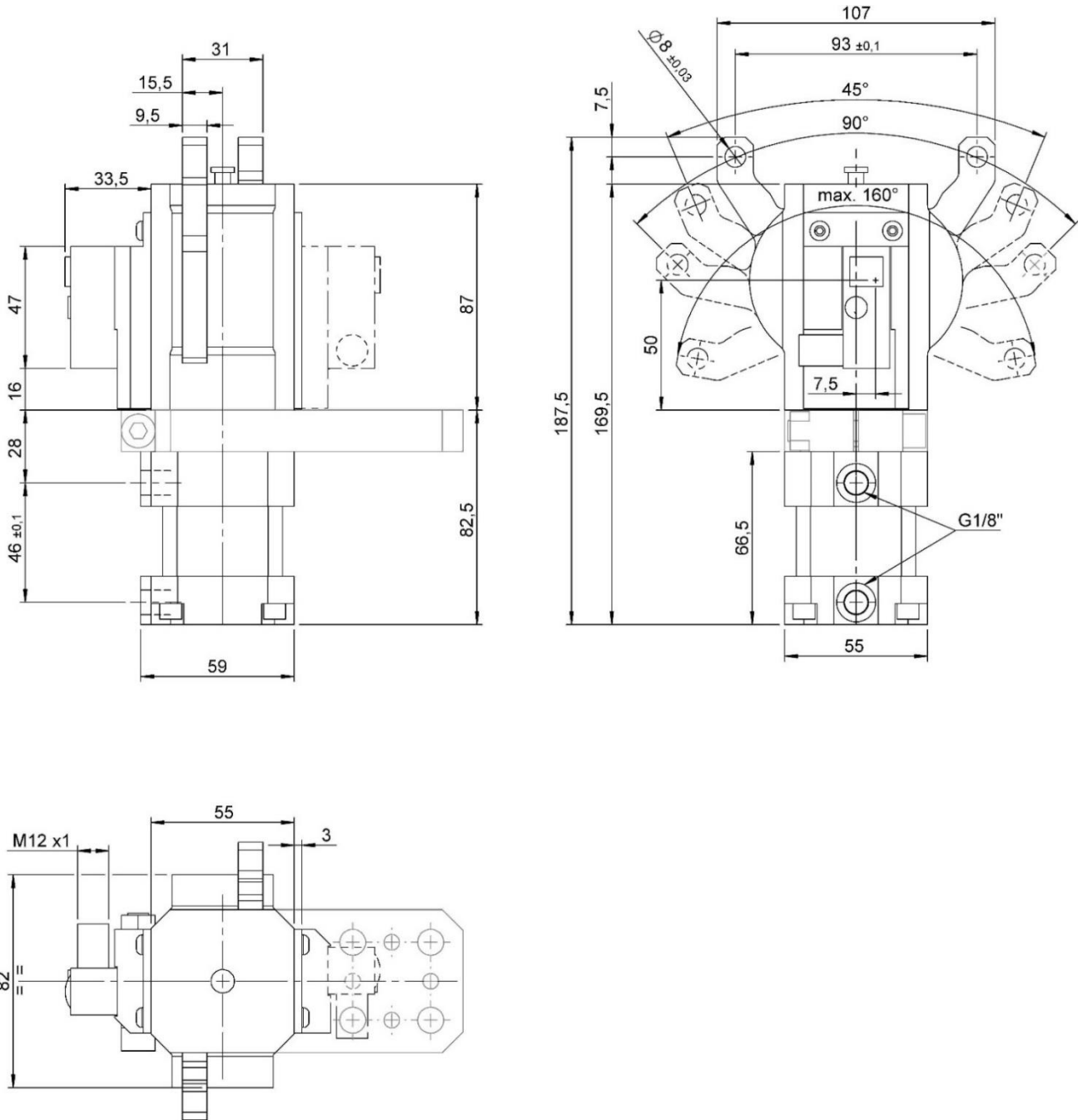

Modello Type	Alesaggio cilindro Cylinder bore	Compensazione spessore lamiera Metal sheet compensation	Forza di bloccaggio (5 bar) Clamping force (5 bar)	Peso Weight	Pressione di lavoro Working pressure	Angoli d'apertura Opening angle
	[ mm ]	[ mm ]	[ N ]	[ Kg ]	[ bar ]	[ ° ]
B40-BX...	40	0	600	~ 2,5	4 - 8	45° - 90° - 160°
B40V-BX...		3	460			



**B40-B1...**

Gripper D. 40, braccio doppio, 1 pin, fissaggio standard  
Gripper D. 40, double arm, 1 pin, standard fixing plate

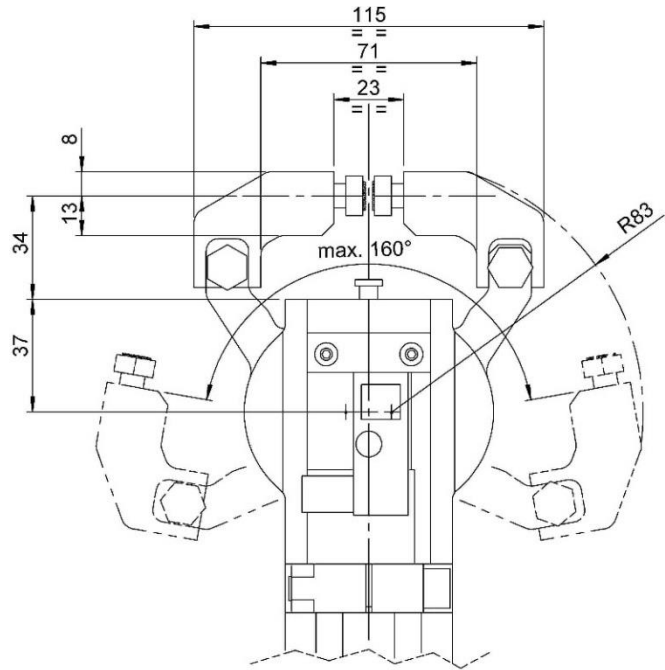
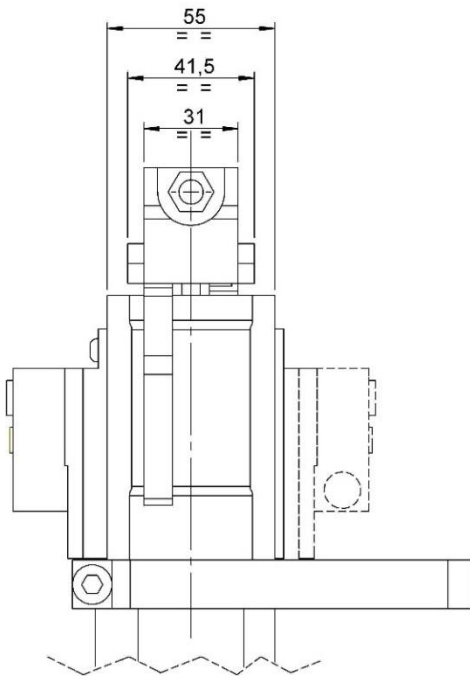

**B40-B2...**

Gripper D. 40, braccio doppio, 2 pins, fissaggio standard  
Gripper D. 40, double arm, 2 pins, standard fixing plate

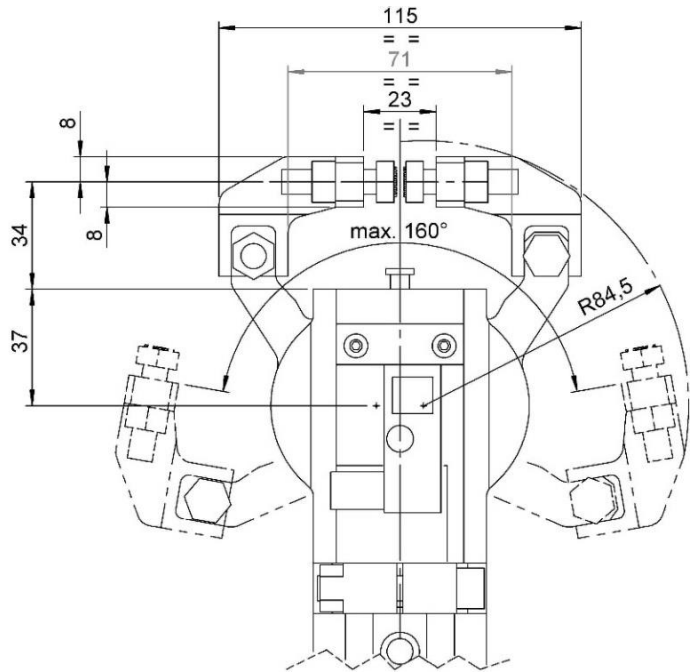
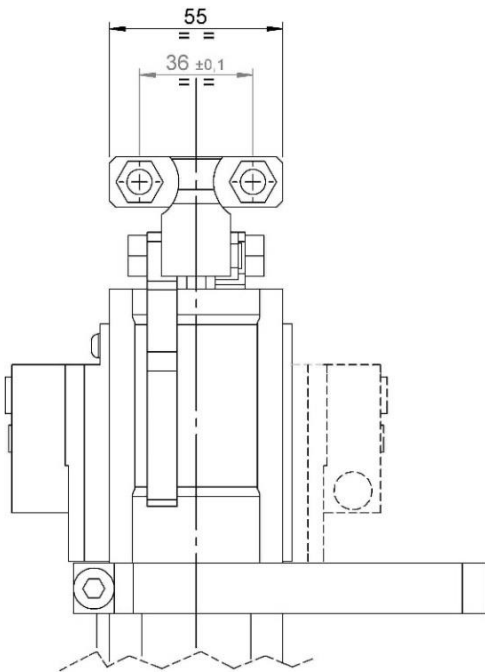

Modello Type	Alesaggio cilindro Cylinder bore	Compensazione spessore lamiera Metal sheet compensation	Forza di bloccaggio (5 bar) Clamping force (5 bar)	Peso Weight	Pressione di lavoro Working pressure	Angoli d'apertura Opening angle
	[ mm ]	[ mm ]	[ N ]	[ Kg ]	[ bar ]	[ ° ]
B40-B...	40	0	600	~ 2,5	4 - 8	45° - 90° - 160°
B40V-B...		3	460			



**Tipi di piastre di fissaggio.**

**Type of fixing plates.**

**B40.....-A**

**Piastra tipo A (standard)**  
**Plate type A (standard)**

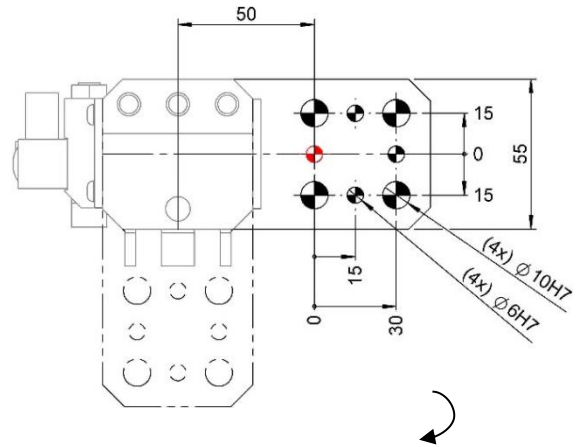
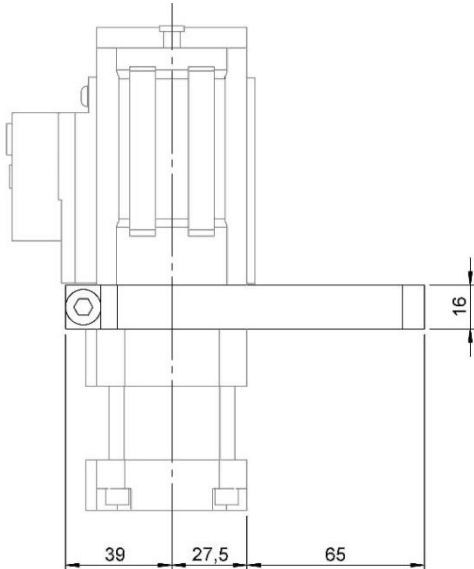

Possibilità di rotazione della piastra di 360°  
Possibility to rotate the plate of 360°

Tolleranze: fori spina ±0.02, fori filettati: ±0.1  
Tolerances: dowel holes ±0.02, screw holes ±0.1

**B40.....-B30**

**Piastra tipo B30**  
**Plate type B30**

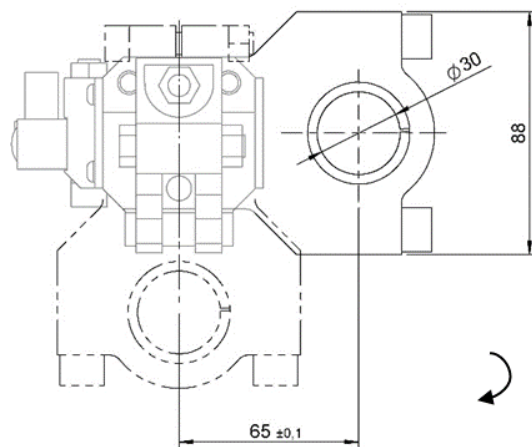
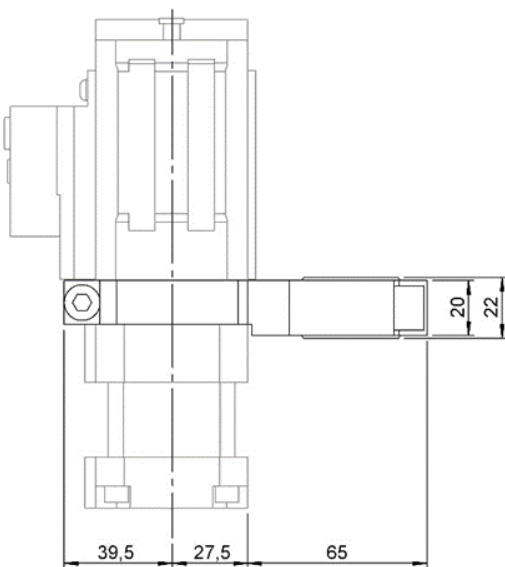

Possibilità di rotazione della piastra di 360°  
Possibility to rotate the plate of 360°



**Tipi di piastre di fissaggio.**

**Type of fixing plates.**

B40.....-B40

**Piastra tipo B40**  
**Plate type B40**

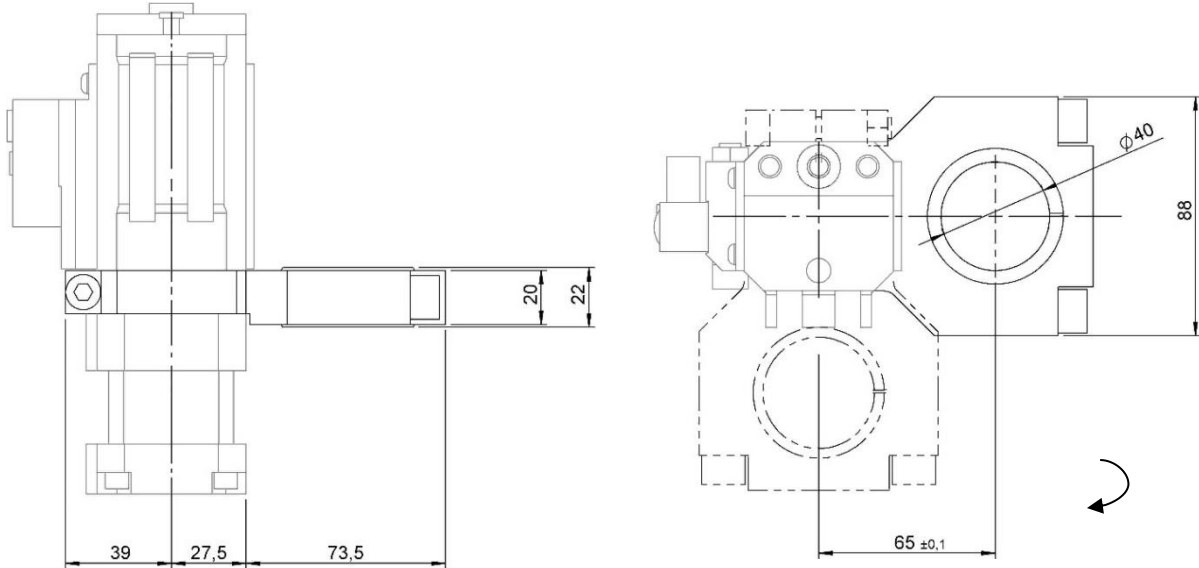

Possibilità di rotazione della piastra di 360°  
Possibility to rotate the plate of 360°

B40.....-C

**Piastra tipo C\***  
**Plate type C\***

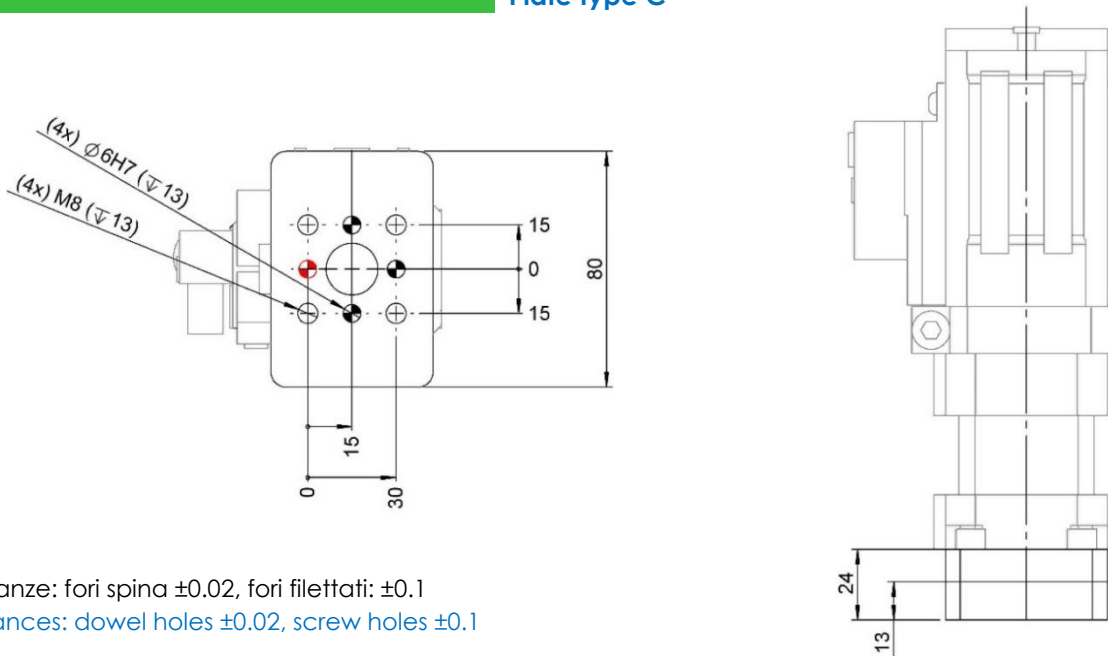

Tolleranze: fori spina  $\pm 0.02$ , fori filettati:  $\pm 0.1$   
Tolerances: dowel holes  $\pm 0.02$ , screw holes  $\pm 0.1$

\* L'attacco tipo C richiede per poter essere montato la presenza di una piastra/distanziale tra il cilindro ed il corpo del gripper. Codice d'ordine **06538/C**

\* To mount the fixing type C, it's necessary to mount a plate/spacer between the cylinder and the gripper. Order code **06538/C**

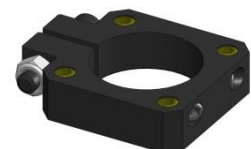



Di seguito vengono riportate le inclinazioni massime ottenibili con l'applicazione degli attacchi con snodo sferico descritti in precedenza (B30, B40).

Describe below the maximum inclinations that can obtain with the use of mounts with ball joint described previously (B30, B40).

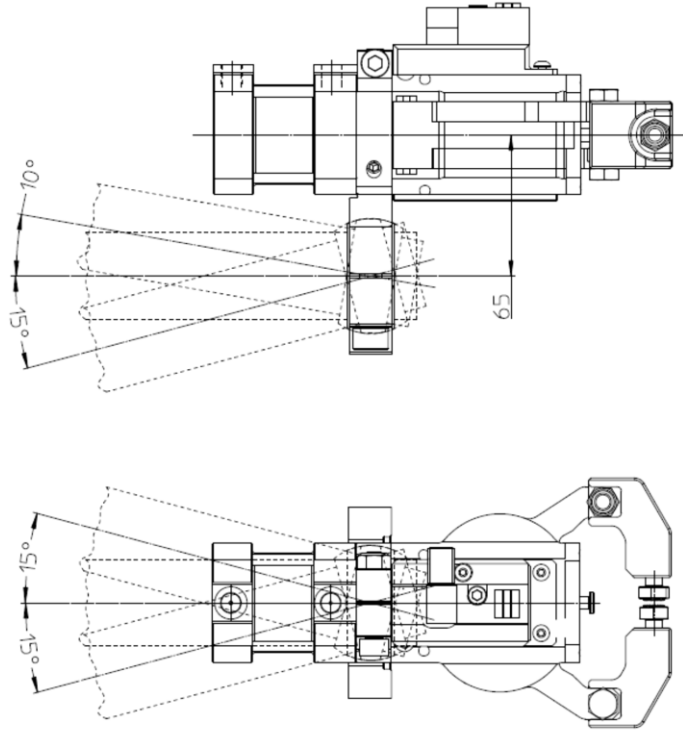

Su richiesta sono fornibili tasselli speciali o si possono costruire tasselli rispettando le quote con relative tolleranze riportate di seguito.

On request they are available special blocks or they can be built respecting the dimensions with it's tolerances.

**Tipo A**  
**Type A**

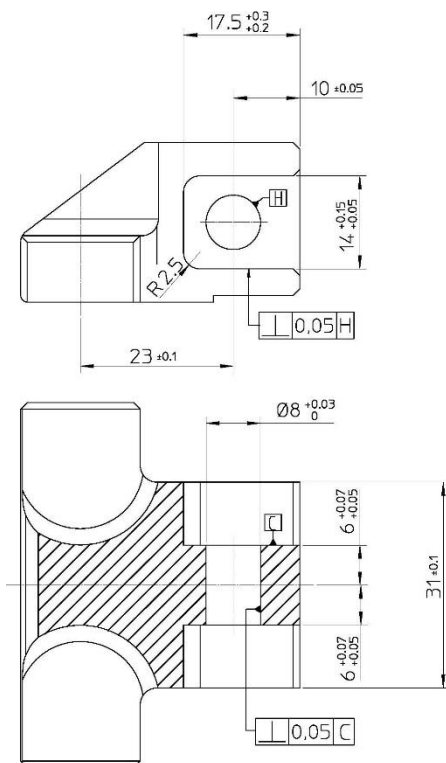

**Tipo B**  
**Type B**

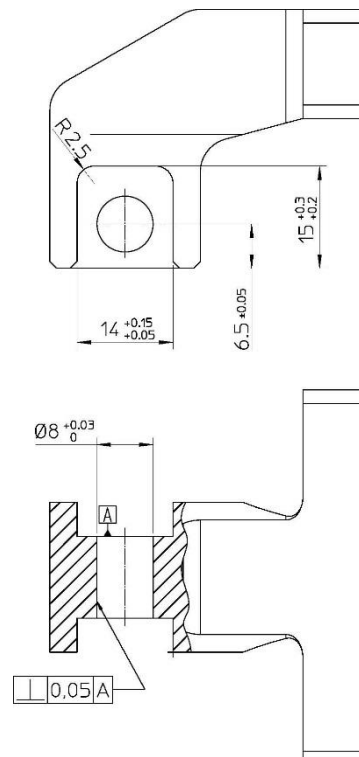



## Diagrammi.

### Diagrams.

#### Diagramma di forza B40

##### Force diagram B40

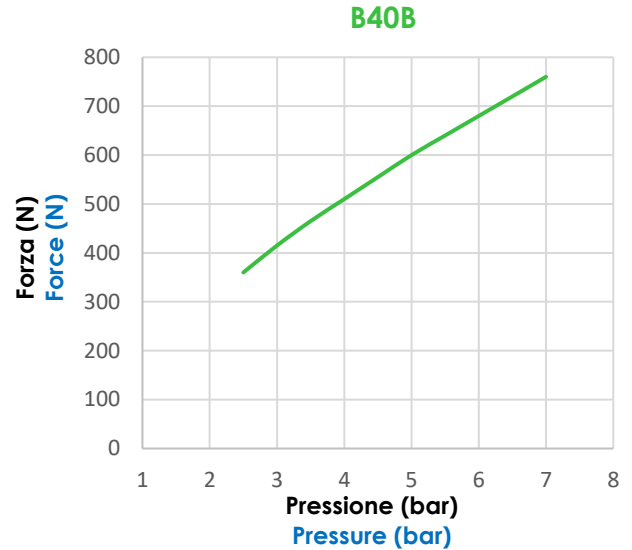
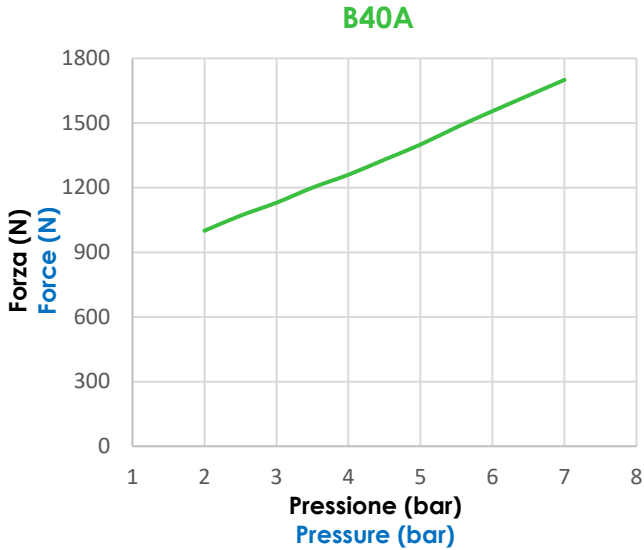

#### Diagramma di forza B40V.

##### Force diagram B40V.

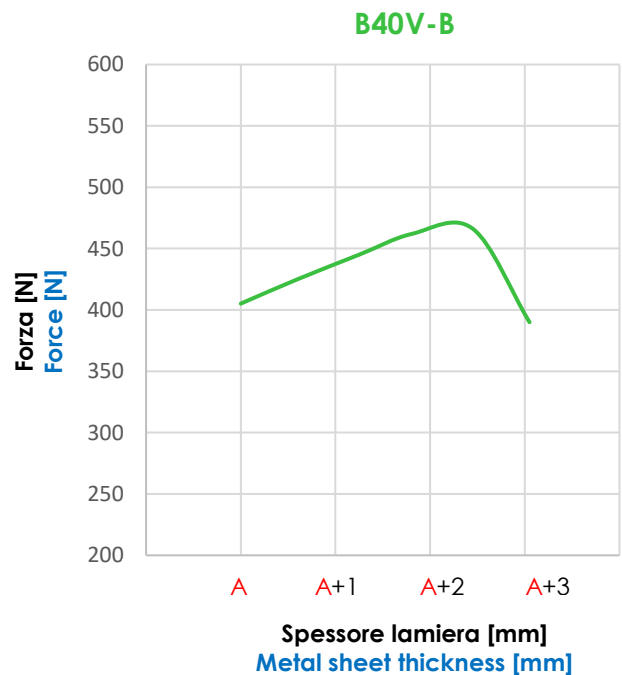
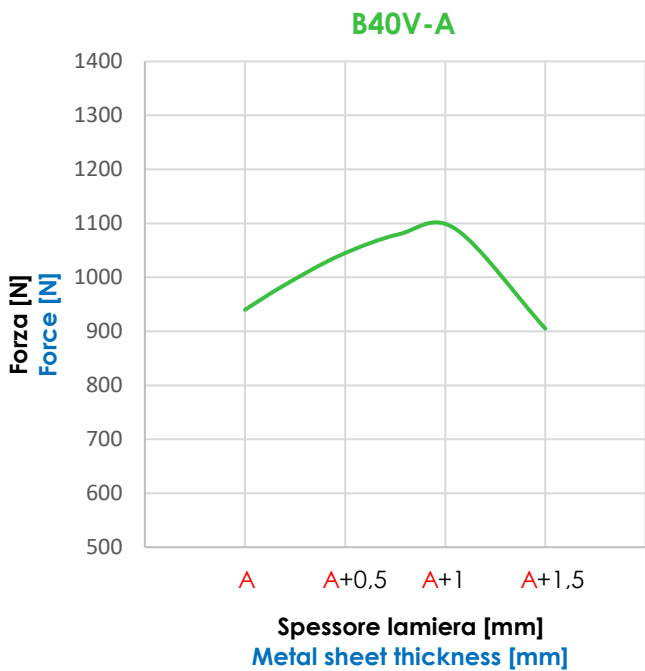

A: spessore lamiera nominale  
nominal metal sheet thickness



## Schema Finecorsa induttivo.

### Diagram for Inductive proximity switch.

Caratteristiche tecniche (P+F):

- Tipo di uscita: PNP;
- Tensione d'alimentazione: 10-30 VDC;
- Corrente max. di commutazione: 200 mA;
- Consumo di corrente: < 25 mA;
- Calo di tensione: < 2 V
- Campo di temperatura: -25° / 70° C.

Technical data (P+F):

- Output type: PNP;
- Feeding voltage: 10-30 VDC;
- Max. commutating current: 200 mA;
- Power supply: < 25 mA;
- Voltage drop: < 2 V;
- Temperature range: -25° / 70° C.

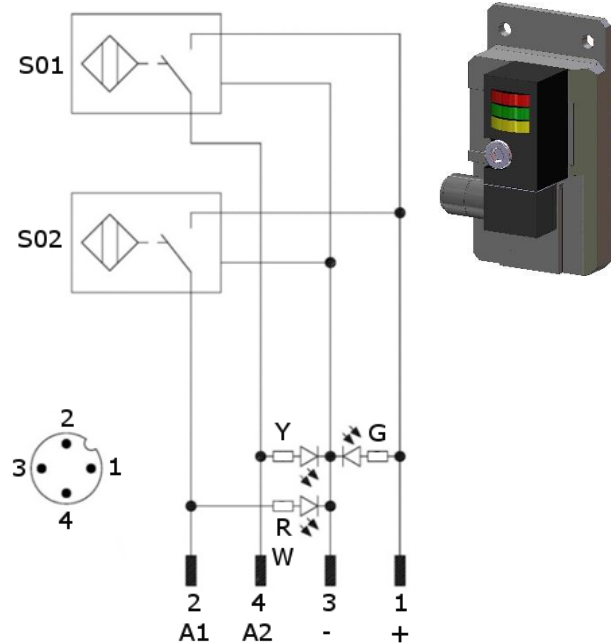

- cod. 06403/R/C** per finecorsa standard con LED rosso
- cod. 06403/W/C** per finecorsa con LED bianco (normativa Porsche).
- cod. 06403/R/C** for standard proximity-switch with red LED;
- cod. 06403/W/C** for proximity-switch with white LED (Porsche normative).

S01 = segnale d'apertura  
 S01 = opening signal  
 S02 = segnale di chiusura  
 S02 = closing signal

Y = LED giallo / yellow LED  
 G = LED verde / green LED  
 R = LED rosso / red LED

1 = filo marrone / brown wire  
 2 = filo nero / black wire  
 3 = filo blu / blue wire  
 4 = filo bianco / white wire

## Schema pneumatico.

### Pneumatic plan.

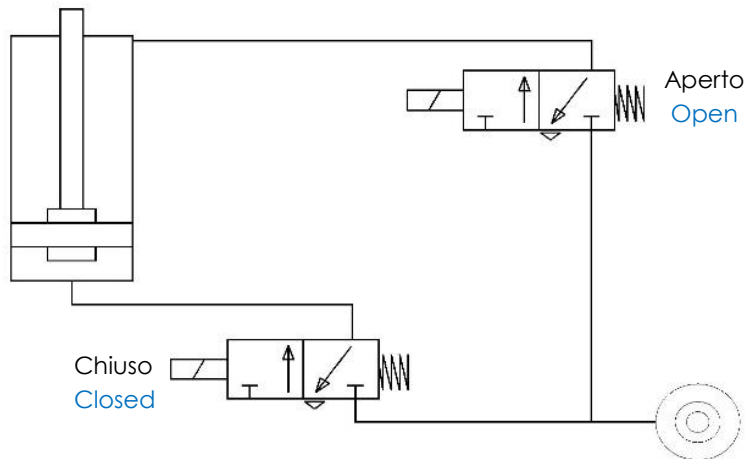

Pressione d'esercizio Working pressure	Angolo d'apertura Opening angle	Angolo d'apertura Opening angle	Consumo d'aria Air consumption (5 bar)
	B40A / B40V-A	B40B / B40V-B	
[ bar ]	[ ° ]	[ ° ]	[ l ]
4 – 8	22,5	45	0,20
	45	90	0,25
	80	160	0,30



## Gripper pneumatici B40 – B40V Pneumatic grippers B40 – B40V

### Caratteristiche principali:

- Corpo in acciaio
- Irreversibilità della posizione di bloccaggio
- Bracci in acciaio tipo A e B
- 4 tipologie di attacchi
- Cilindro pneumatico alesaggio 40 mm
- 2 fori di connessione aria G1/8"
- Finecorsa induttivo 3 led (connessione M12x1)
- B40V: compensazione spessore lamiera



### Main characteristics:

- Steel body
- Irreversibility of clamping position
- Steel arms type A e B
- 4 type of fixing plates
- Pneumatic cylinder bore 40 mm
- 2 feeding ports G1/8"
- Inductive proximity switch 3 leds (connection M12x1)
- B40V: sheet metal thickness compensation



[PDF](#)



[3D Step](#)



[WEB](#)

### Indice. Index.

Pagina Page	Descrizione Description
1	Caratteristiche principali <a href="#">Main characteristics</a>
2	Codice d'ordine <a href="#">Ordering example</a>
3	B40-AX...
4	B40-A1...
5	B40-A2...
6	B40-BX...
6	B40-B1...
6	B40-B2...
7-9	Tipi di piastre di fissaggio <a href="#">Type of fixing plates</a>
10	Diagrammi / Consumo d'aria <a href="#">Diagrams / Air consumption</a>
11	Schema finecorsa induttivo / Schema pneumatico <a href="#">Diagram for inductive proximity switch / Pneumatic plan</a>
12	Ricambi / <a href="#">Spare parts</a>
13	Note / <a href="#">Notes</a>