



Dispositivo di scorrimento lineare SLG40

Linear unit SLG40

Caratteristiche principali:

- Corsa regolabile con intervalli di 0,1 mm
- Cilindro pneumatico alesaggio 40 mm
- Sistema di bloccaggio ad innesto (SBI)
- Ripetibilità: $\pm 0,02$ mm
- Posizione di bloccaggio in apertura e chiusura
- Frenatura cilindro in posizione di apertura (standard)
- Deceleratore in posizione di chiusura
- Sensori di posizione in apertura ed in chiusura
- Sensori induttivi di posizione SBI

Main characteristics:

- Adjustable stroke with 0,1 mm intervals
- Pneumatic cylinder with 40 mm bore
- Locking device system
- Repeatability: $\pm 0,02$ mm
- Locking position in the opening and closing position
- Cylinder cushion in the opening position (standard)
- Shock absorber in the closing position
- Proximity switches in the opening and closing position
- Proximity switches for SBI

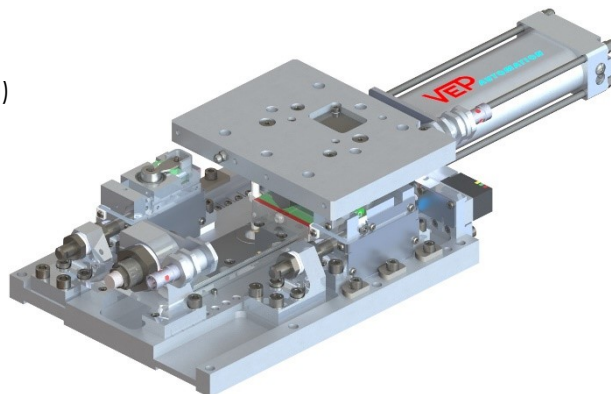
[PDF](#)

[3D Step](#)

[Index](#)

Indice.

Index.

Pagina Page	Descrizione Description	
1	Caratteristiche principali Main characteristics	
2	Codice d'ordine Ordering example	
3	Pagina dimensionale Dimensional page	SLG40-.../...-D-X-H
4		SLG40-.../...-V-X-H
5		SLG40-.../...-H-X-H
6		Foratura fissaggio inferiore Bottom fixing holes
13	Schema sensore induttivo SBI / Finecorsa Diagram for inductive sensor for SBI / Limit switch	
14	Schema pneumatico Pneumatic plan	
15-16	Ricambi / Spare parts	
16	Note / Notes	



Codice d'ordine.
Ordering example.

SLG40 - 100 / 60 - D - X - H

SLG40
 alesaggio Ø 40 mm,
 1 carrello, carico max. 25 Kg
 cylinder bore Ø 40 mm,
 1 runner block, max. load 25 Kg

Tipo Type	Corsa Adjustable stroke
50	1÷50 mm
100	51÷100 mm
150	101÷150 mm
200	151÷200 mm
250	201÷250 mm
300	251÷300 mm

Otturatore:
Locking device:

D: otturatore in pos. riposo ed in pos. lavoro
 Locking device in front and back position

V: otturatore in pos. lavoro
 Locking device in front position

H: otturatore in pos. riposo
 Locking device in back position

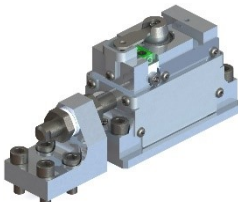

Riparo:
Cover:

X: senza riparo
 without cover

Posizione di montaggio:
Mounting position:

H: orizzontale (standard)
 horizontal (standard)

V: applicazione speciale con posizione di montaggio verticale (capovolta o sul lato)
SOLO dopo approvazione da parte della VEP Automation.
 special application with vertical mounting position (hanging or upright)
ONLY after the approval of VEP AUTOMATION

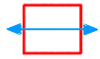

SLG40-... / ...-D-X-H

Slitta lineare, D.40, 1 carrello, doppio otturatore, Corsa vario
 Linear unit, D.40, 1 Runner block, double locking dev, Various stroke

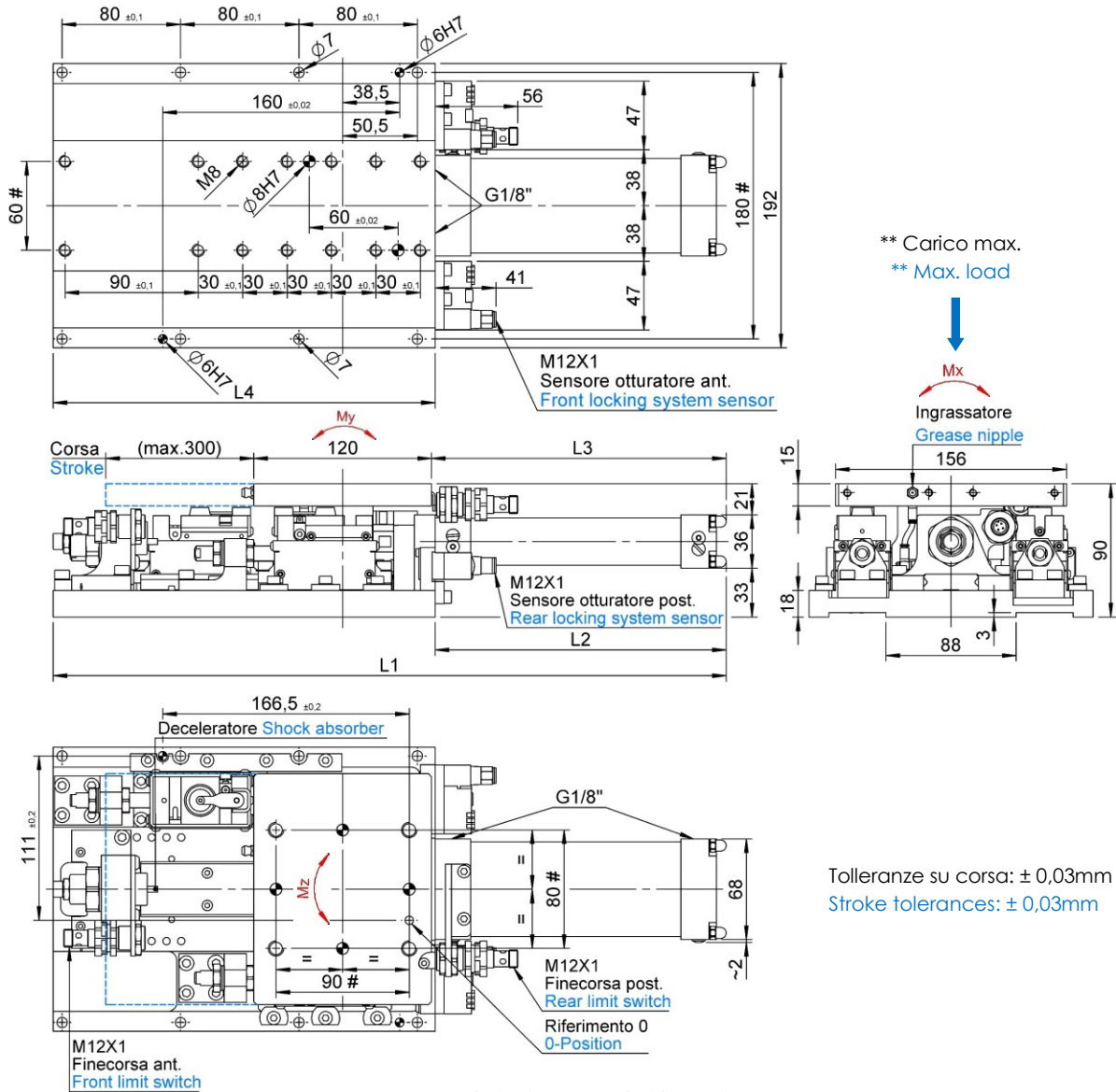

Tolleranze su corsa: $\pm 0,03\text{mm}$
 Stroke tolerances: $\pm 0,03\text{mm}$

#Tolleranze: fori spina $\pm 0,02$, fori filettati $\pm 0,1$
 #Tolerances: dowel holes $\pm 0,02$, screw holes $\pm 0,1$

Modello Type	Tipo Type	Alesaggio Cylinder bore	Corsa regolabile Adjustable stroke	Peso Weight	L1	L2	L3	L4	Consumo aria (5 bar) Air consumption (5 bar)	Pressione d'esercizio Working pressure
		[mm]	[mm]	[kg]	[mm]	[mm]	[mm]	[mm]	[l]	[bar]
SLG40-50	50	40	1 ÷ 50	6,5	343	135	137	208	0,8	5 - 7
SLG40-100	100		51 ÷ 100	7,0	455	197	199	258	1,4	
SLG40-150	150		101 ÷ 150	7,5	555	247	249	308	2,1	
SLG40-200	200		151 ÷ 200	8,0	655	297	299	358	2,9	
SLG40-250	250		201 ÷ 250	8,5	755	347	349	408	3,6	
SLG40-300	300		251 ÷ 300	9,0	855	397	399	458	4,3	

** Carico max. applicabile (5 bar) **Max. applicable load (5 bar)		Momento dinamico max. Dynamic torque max.			Momento statico max. Static moment max.			Spinta max. (5 bar) Max. thrust force (5bar)	
[Kg]		[Nm]			[Nm]			[N]	
Inst. orizzontale Horizontal installation	Inst. verticale Vertical installation	Mx	My	Mz	Mx	My	Mz		
25	15	50	25	25	90	40	40	620	

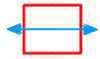

SLG40-... / ...-V-X-H

Slitta lineare, D.40, 1 carrello, otturatore pos. lavoro, Corsa vario
 Linear unit, D.40, 1 Runner block, front locking dev, Various stroke

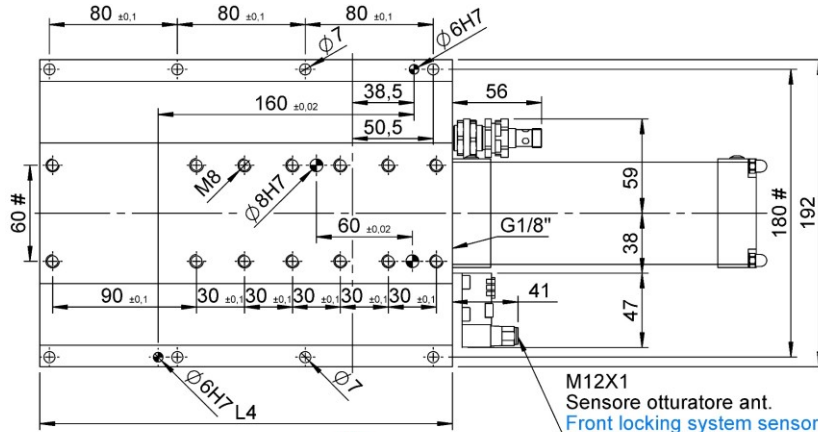

** Carico max.
 ** Max. load



Mx

Ingrassatore
 Grease nipple

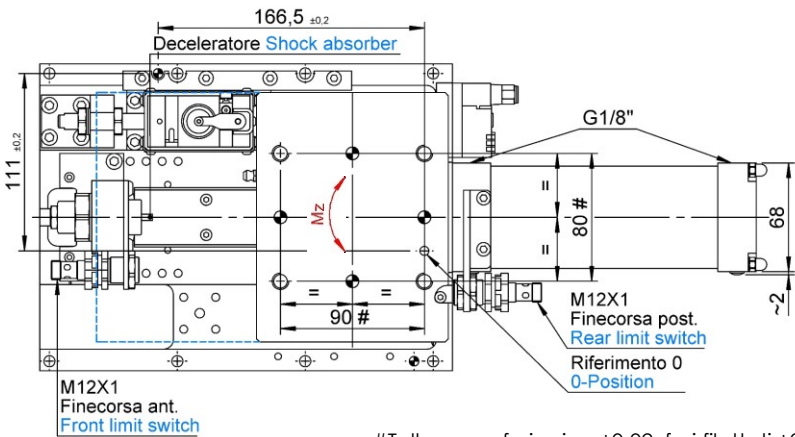
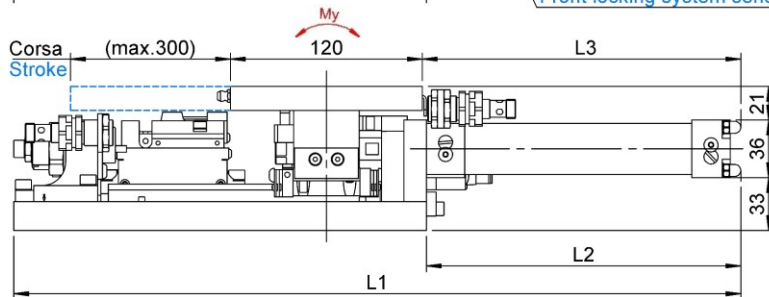
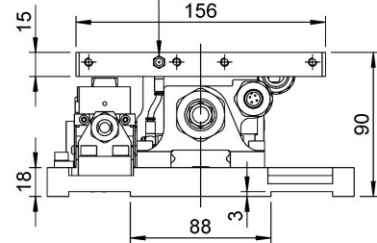

Tolleranze su corsa: ± 0,03mm
 Stroke tolerances: ± 0,03mm

#Tolleranze: fori spina ±0.02, fori filettati ±0.1
 #Tolerances: dowel holes ±0.02, screw holes ±0.1

Modello Type	Tipo Type	Alesaggio Cylinder bore	Corsa regolabile Adjustable stroke	Peso Weight	L1	L2	L3	L4	Consumo aria (5 bar) Air consumption (5 bar)	Pressione d'esercizio Working pressure
		[mm]	[mm]	[kg]	[mm]	[mm]	[mm]	[mm]	[l]	[bar]
SLG40-50	50	40	1 ÷ 50	6,0	343	135	137	208	0,8	5 - 7
SLG40-100	100		51 ÷ 100	6,5	455	197	199	258	1,4	
SLG40-150	150		101 ÷ 150	7,0	555	247	249	308	2,1	
SLG40-200	200		151 ÷ 200	7,5	655	297	299	358	2,9	
SLG40-250	250		201 ÷ 250	8,0	755	347	349	408	3,6	
SLG40-300	300		251 ÷ 300	8,5	855	397	399	458	4,3	

** Carico max. applicabile (5 bar)
 **Max. applicable load (5 bar)

Momento dinamico max.
 Dynamic torque max.

Momento statico max.
 Static moment max.

Spinta max. (5 bar)
 Max. thrust force (5bar)

[Kg]		[Nm]			[Nm]			[N]
Inst. orizzontale Horizontal installation	Inst. verticale Vertical installation	Mx	My	Mz	Mx	My	Mz	
25	15	50	25	25	90	40	40	620

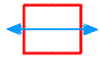

SLG40-... / ...-H-X-H

Slitta lineare, D.40, 1 carrello, otturatore pos. riposo, Corsa vario
 Linear unit, D.40, 1 Runner block, back locking dev, Various stroke

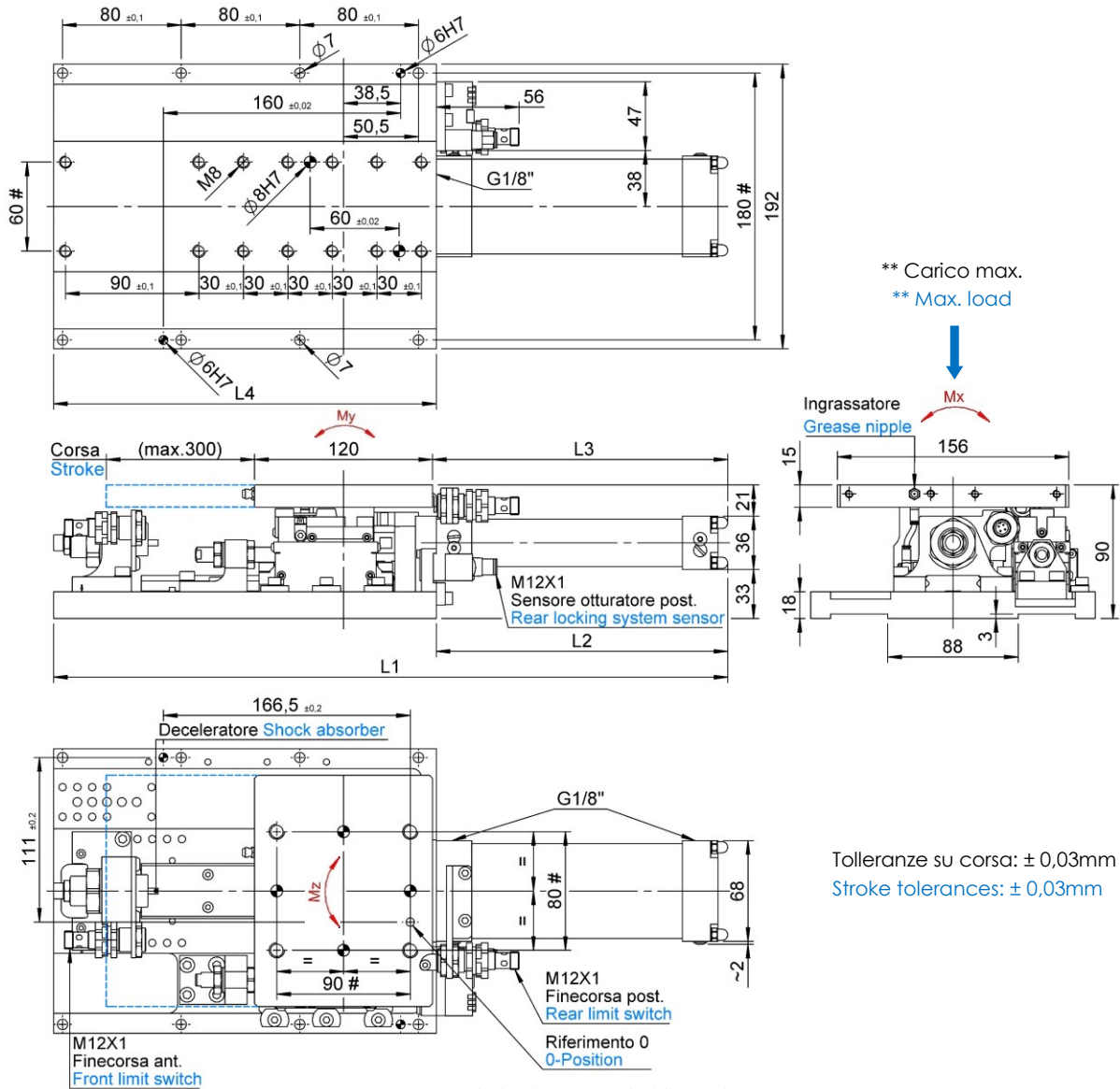

#Tolleranze: fori spina ±0.02, fori filettati ±0.1
 #Tolerances: dowel holes ±0.02, screw holes ±0.1

Modello Type	Tipo Type	Alesaggio Cylinder bore	Corsa regolabile Adjustable stroke	Peso Weight	L1	L2	L3	L4	Consumo aria (5 bar) Air consumption (5 bar)	Pressione d'esercizio Working pressure
		[mm]	[mm]	[kg]	[mm]	[mm]	[mm]	[mm]	[l]	[bar]
SLG40-50	50	40	1 ÷ 50	6,0	343	135	137	208	0,8	5 - 7
SLG40-100	100		51 ÷ 100	6,5	455	197	199	258	1,4	
SLG40-150	150		101 ÷ 150	7,0	555	247	249	308	2,1	
SLG40-200	200		151 ÷ 200	7,5	655	297	299	358	2,9	
SLG40-250	250		201 ÷ 250	8,0	755	347	349	408	3,6	
SLG40-300	300		251 ÷ 300	8,5	855	397	399	458	4,3	

** Carico max. applicabile (5 bar) **Max. applicable load (5 bar)		Momento dinamico max. Dynamic torque max.			Momento statico max. Static moment max.			Spinta max. (5 bar) Max. thrust force (5bar)	
[Kg]		[Nm]			[Nm]			[N]	
Inst. orizzontale Horizontal installation	Inst. verticale Vertical installation	Mx	My	Mz	Mx	My	Mz		
25	15	50	25	25	90	40	40	620	

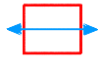

Foratura per fissaggio inferiore.

Bottom fixing holes.

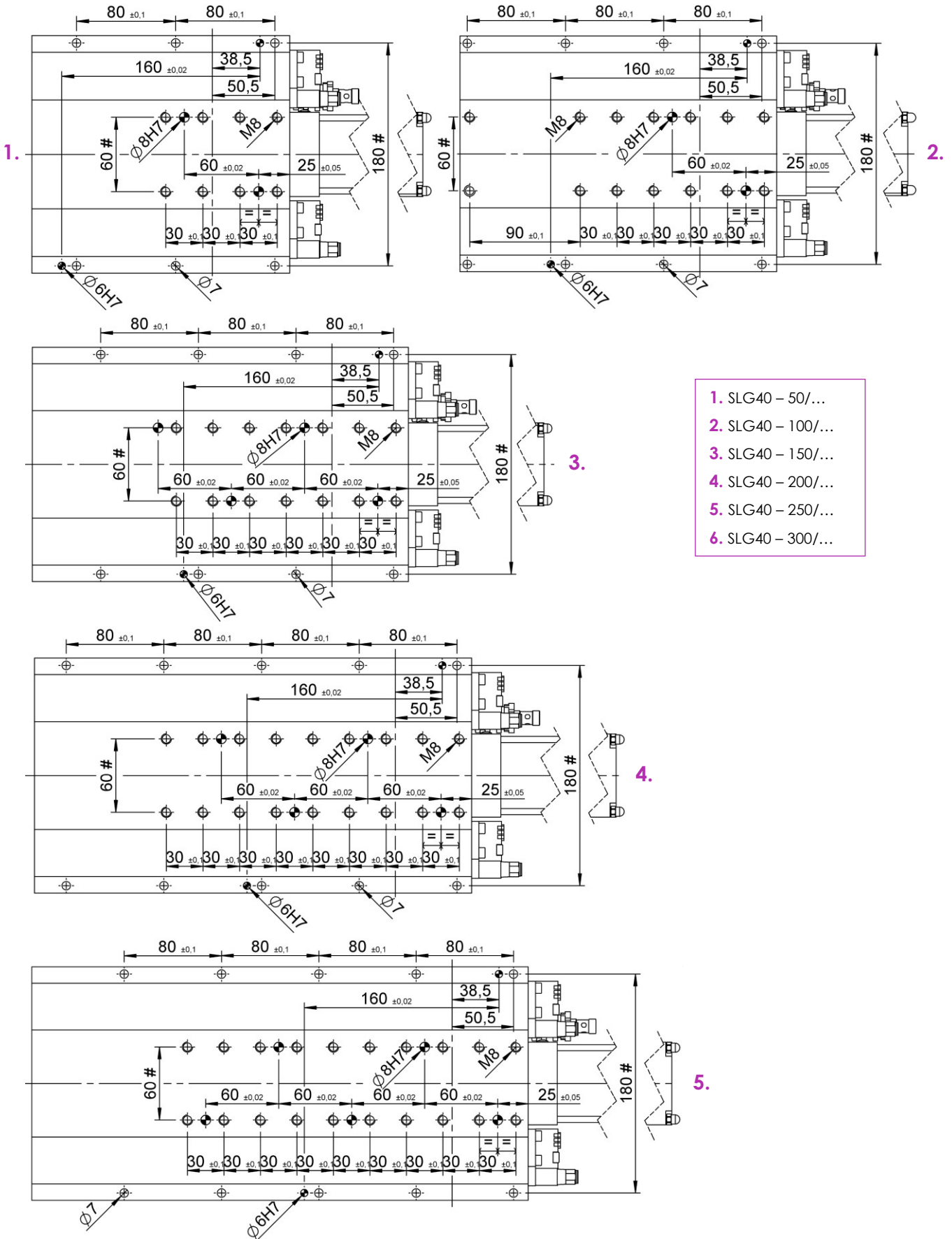

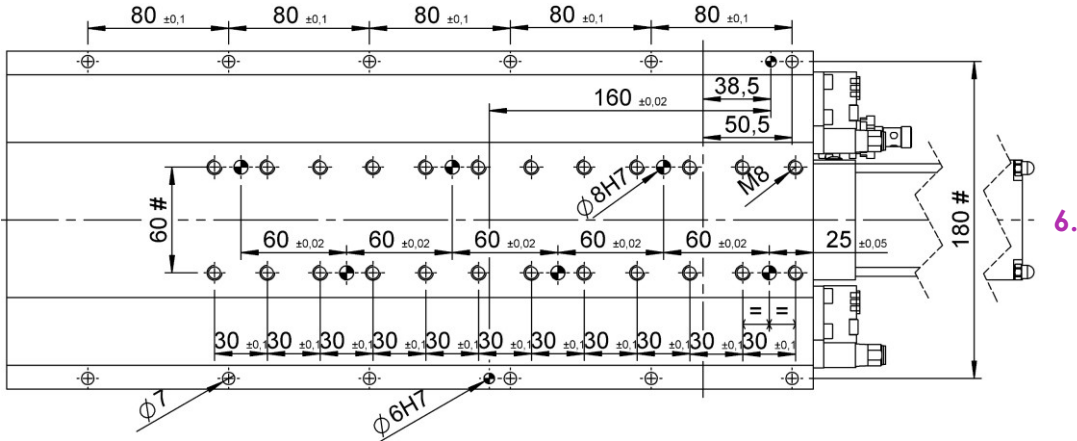
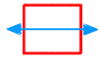

Schema sensore posizione otturatore.

Locking device sensor diagram.

Caratteristiche tecniche:

- Tipo di uscita: PNP
- Tensione d'alimentazione: 10-30 VDC;
- Corrente max. di commutazione: 200 mA;
- Consumo di corrente: < 25 mA;
- Calo di tensione: < 2 V
- Campo di temperatura: -25° / 70° C.

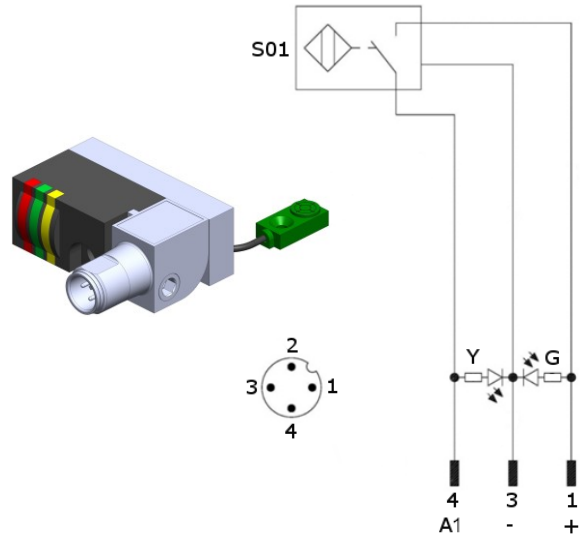

Technical data:

- Output type: PNP
- Feeding voltage: 10-30 VDC;
- Max. commutating current: 200 mA;
- Power supply: < 25 mA;
- Voltage drop: < 2 V;
- Temperature range: -25° / 70° C.

S01 = segnale d'apertura
S01 = opening signal

Y = LED giallo / yellow LED
G = LED verde / green LED

1 = filo marrone / brown wire
3 = filo blu / blue wire
4 = filo bianco / white wire

Schema sensore di posizione

Limit switch diagram

Caratteristiche tecniche:

- Tipo di uscita: PNP
- Tensione d'alimentazione: 10-30 VDC;
- Corrente max. di commutazione: 200 mA;
- Campo di temperatura: -25° / 70° C.



Technical data:

- Output type: PNP
- Feeding voltage: 10-30 VDC;
- Max. commutating current: 200 mA;
- Temperature range: -25° / 70° C.

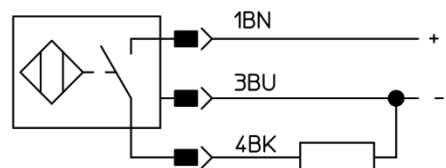



Schema pneumatico.

Pneumatic plan.

Valvola di comando 5/2

Control valve 5/2

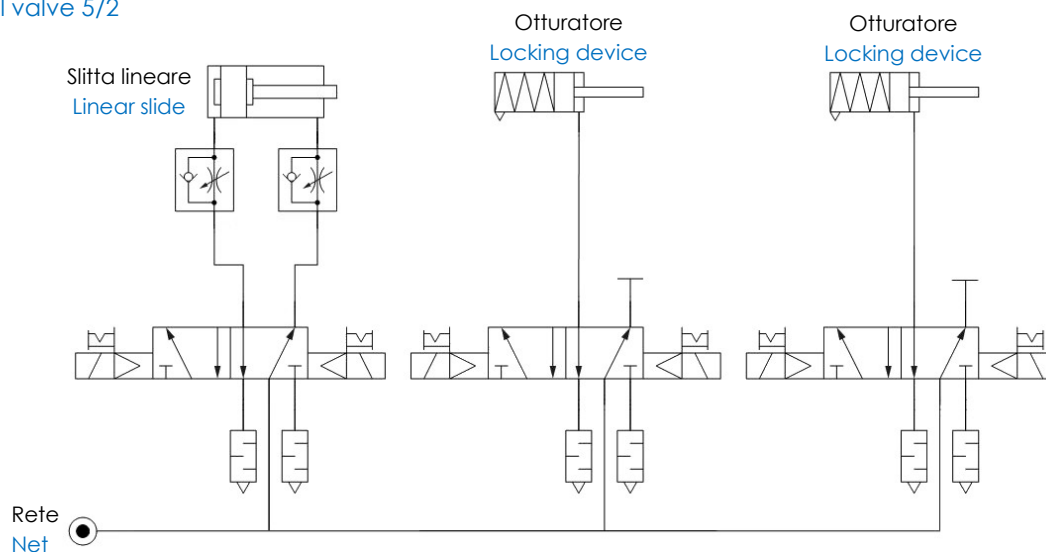

Ricambi.

Spare parts.

# Kit	Immagine Picture	Descrizione Description	Articolo Article
Kit guarnizioni Seals kit		Kit guarnizioni Seals kit	SCR-SLD40.1
Cilindro pneumatico Pneumatic cylinder		Cilindro pneumatico completo Complete pneumatic cylinder	09058/corsa/C 09058/stroke/C
Cilindro otturatore Locking dev. cylinder		Cilindro otturatore Locking device cylinder	09090/C
Sensore otturatore Locking dev. sensor		Sensore completo otturatore da corsa 0 a 150 Complete locking dev. sensor from stroke 0 to 150	3/412/C
		Sensore completo otturatore da corsa 151 a 300 Complete locking dev. sensor from stroke 151 to 300	3/411/C
Satelliti Sensor's satellite		Satelliti da corsa 0 a 150 Sensor's satellite from stroke 0 to 150	3/412
		Satelliti da corsa 151 a 300 Sensor's satellite from stroke 151 to 300	3/411
Blocchetto amplificatore Power amplifier		Blocchetto amplificatore LED rosso Power amplifier red LED	3/413
Spessori Shims		Spessori regolazione sensore otturatore Shims for locking device adjustment	09085/0,3/C