



Chiusura pneumatica CPR25

Pneumatic clamp CPR25

Caratteristiche principali:

- Fianchetti in alluminio
- Dispositivo a ginocchiera
- Angolo di apertura facilmente modificabile
- Leve versatili in acciaio VC e OC
- 3 possibilità di staffaggio (fronte, retro e sul cilindro Ø30 mm)
- Alesaggio del cilindro pneumatico: 25 mm
- 5 fori di connessione G1/8"
- Finecorsa induttivo VEP (connessione M12x1)



Main characteristics:

- Aluminum flanks
- Toggle action mechanism
- Opening angle easily adjustable
- Versatile steel arms VC and OC
- 3 mounting areas (front, back and on the cylinder Ø30 mm)
- Pneumatic cylinder bore: 25 mm
- 5 feeding ports G1/8"
- Inductive proximity switch VEP (connection M12x1)

[PDF](#)[3D Step](#)[WEB](#)

Indice. Index.

Pagina Page	Descrizione Description	
1	Caratteristiche principali Main characteristics	
2	Codice d'ordine Ordering example	
3	Pagina dimensionale Dimensional page	C25-VCI ...
4		C25-OCI...
5		C25-G2...
6	Diagrammi Diagrams	
7	Schema finecorsa induttivo / Schema pneumatico Diagram for inductive proximity switch / Pneumatic plan	
8	Istruzioni operative Operating instructions	Modifica angolo d'apertura Opening angle change
9	Ricambi / Spare parts	
10	Note / Notes	



Codice d'ordine. Ordering example.

C25	-	VC	-	I	-	105	-	* C
-----	---	----	---	---	---	-----	---	--------

Modello ed alesaggio cilindro:
Model and cylinder bore:

C25
chiusura standard CPR
(alesaggio cilindro 25 mm)
standard clamp CPR
(cylinder bore 25 mm)

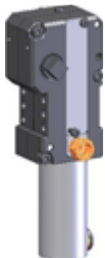

Finecorsa:
Proximity switch:

X: senza finecorsa
without proximity switch

I: finecorsa induttivo VEP
inductive proximity switch VEP



Tipologia leva:
Type of arm:

XX: senza leva
without arm

VC: leva "V" centrale (vedere pag. 3)
arm "V" central (see page 3)

OC: leva "O" centrale (vedere pag. 4)
arm "O" central (see page 4)

G2: leva tipo "G" con 2 perni e
senza supporto fisso (vedere pag. 5)
arm type "G" with 2 pins and
without fixed support (see page 5)

G2/2: leva tipo "G" con 2 perni e
con supporto fisso (vedere pag. 5)
arm type "G" with 2 pins and
with fixed support (see page 5)

N.B.: è possibile trasformare la chiusura tipo VC nel tipo OC semplicemente cambiando la posizione della leva.
NOTE: It's possible to transform the clamp type VC into the type OC simply changing the arm position.



Angolo d'apertura:
Opening angle:

15°	30°	45°	60°	75°	90°	105°
-----	-----	-----	-----	-----	-----	------

Tipologia perni di bloccaggio (vedere pag. 09):
Type of lockpin (see page 9):

X: senza perno
without pin

A: perno con testa esagonale
pin with hexagonal knurled head

B: perno con testa bombata
pin with rounded head

C: perno con testa oscillante zigrinata
pin with swinging knurled head

D: perno con testa in gomma
pin with rubber head

* Da indicare solo per leve tipo "G2"
* Indicate only for clamping arm type "G2"



C25-VC...

Chiusura, D.25, Ang. Vario, Leva Verticale, Offset 0mm
 Clamp, D.25, Vario Op. Angle, Vertical Arm, Offset 0mm

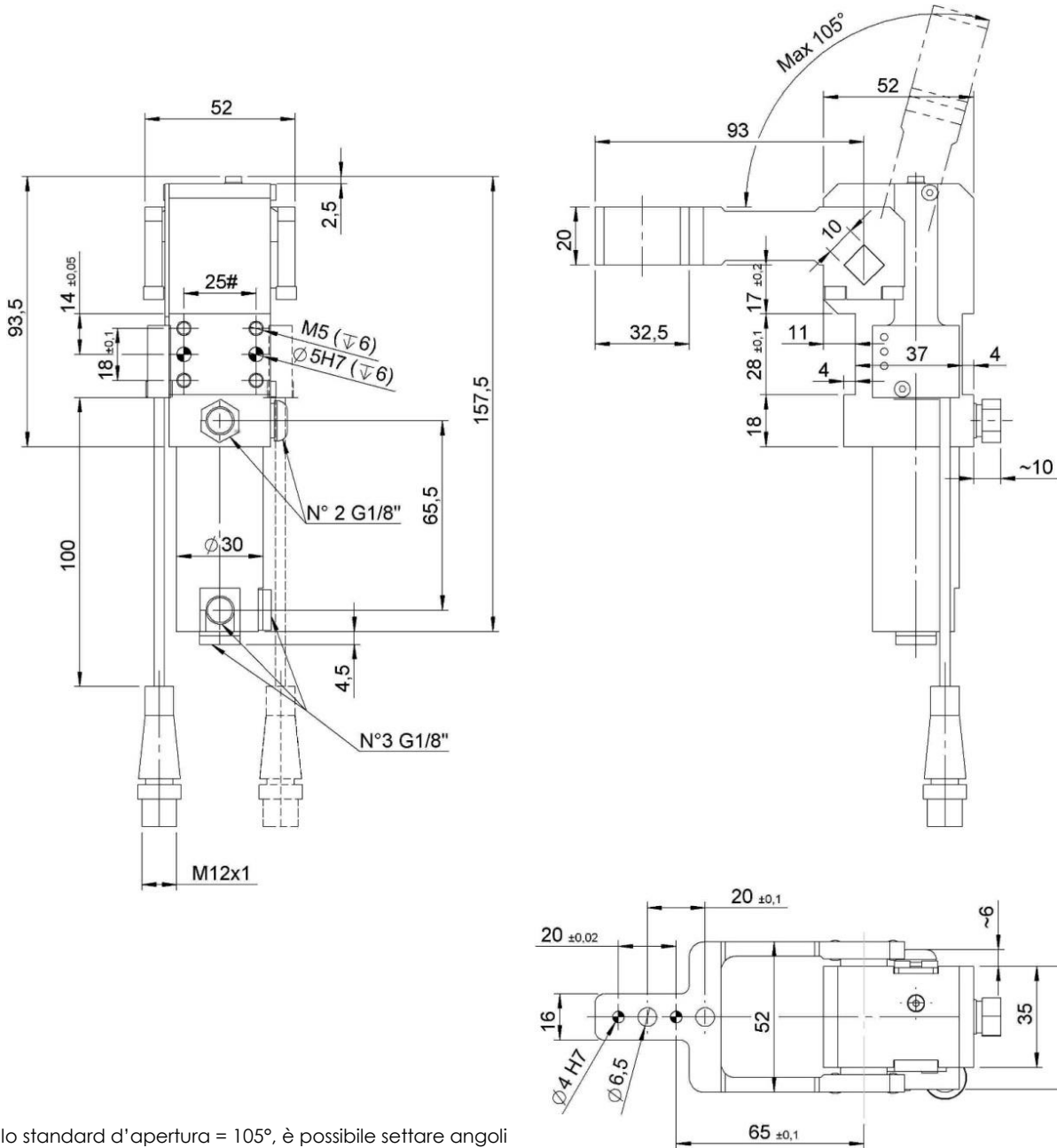

Angolo standard d'apertura = 105°, è possibile settare angoli inferiori ad intervalli di 15°.

Standard opening angle = 105°, it's possible to set a lower angles with steps of 15°.

#Tolleranze: fori spina ±0.02, fori filettati ±0.1
 #Tolerances: dowel holes ±0.02, screw holes ±0.1

Modello Type	Alesaggio cilindro Cylinder bore	Momento di ritegno Holding moment	Peso Weight	Pressione d'esercizio Working pressure	Coppia max di bloccaggio (5 bar) Clamping max. torque (5 bar)	Consumo d'aria (5 bar) Air consumption (5 bar)
	[mm]	[Nm]	[Kg]	[bar]	[Nm]	[l]
C25-VC...	25	75	~ 0.9	2 - 8	30	~ 0.2



C25-OC...

Chiusura, D.25, Ang. Vario, Leva Orizzontale, Offset 0mm
 Clamp, D.25, Vario Op. Angle, Horizontal arm, Offset 0mm

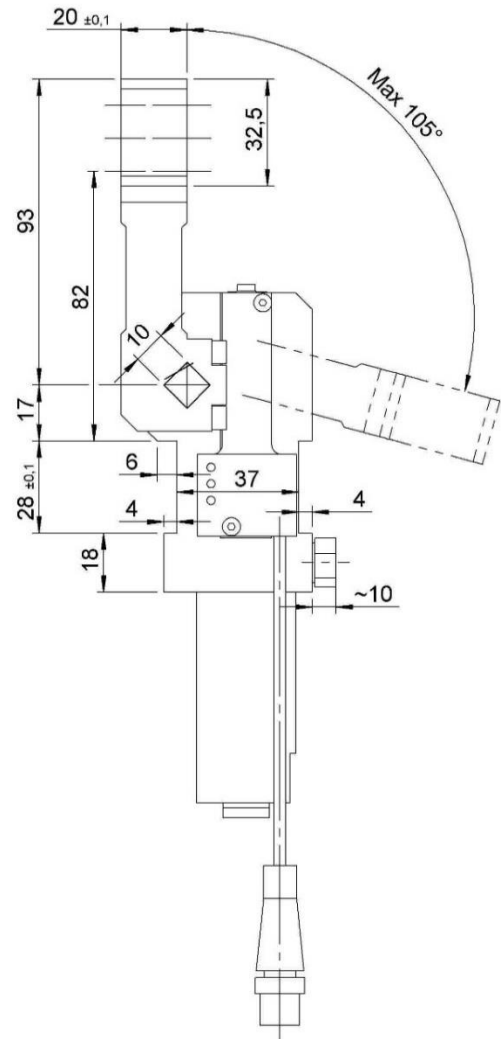
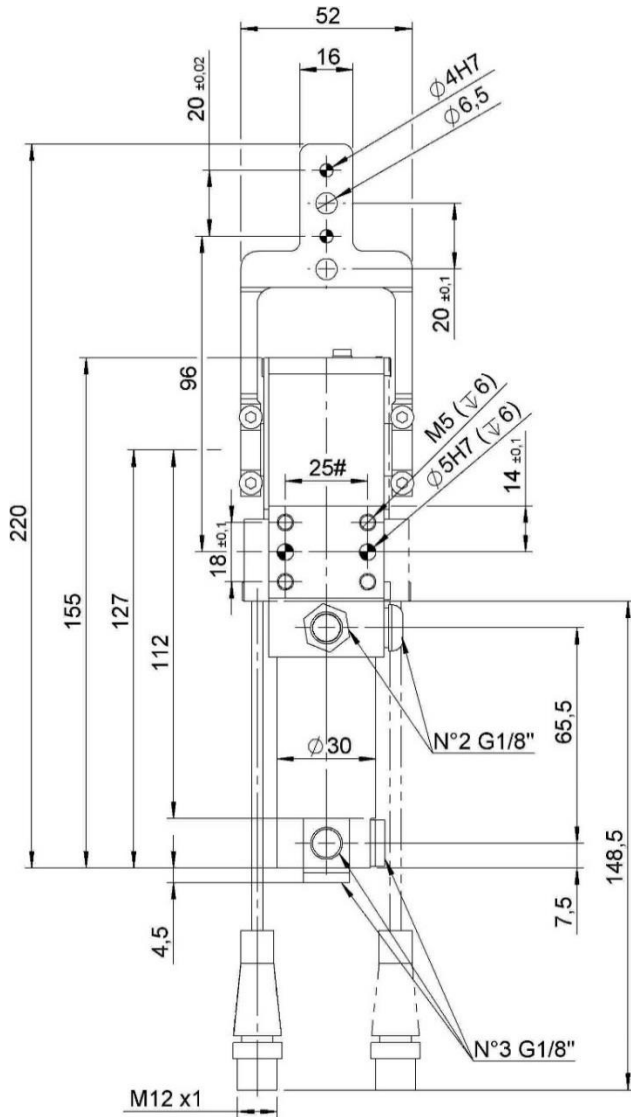

Angolo standard d'apertura = 105°, è possibile settare angoli inferiori ad intervalli di 15°.

Standard opening angle = 105°, it's possible to set a lower angles with steps of 15°.

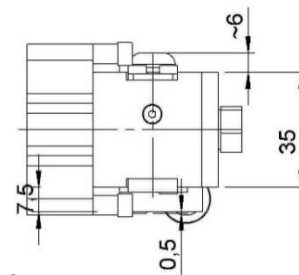

#Tolleranze: fori spina ±0.02, fori filettati ±0.1
 #Tolerances: dowel holes ±0.02, screw holes ±0.1

Modello Type	Alesaggio cilindro Cylinder bore	Momento di ritegno Holding moment	Peso Weight	Pressione d'esercizio Working pressure	Coppia max di bloccaggio (5 bar) Clamping max. torque (5 bar)	Consumo d'aria (5 bar) Air consumption (5 bar)
	[mm]	[Nm]	[Kg]	[bar]	[Nm]	[l]
C25-OC...	25	75	~ 0.9	2 - 8	30	~ 0.2



C25-G2...

Chiusura, D.25, Ang. Vario, Leva Gripper, 2+2 pins, supporto fisso
 Clamp, D.25, Vario Op. Angle, Gripper arm, 2+2 pins, fixed support

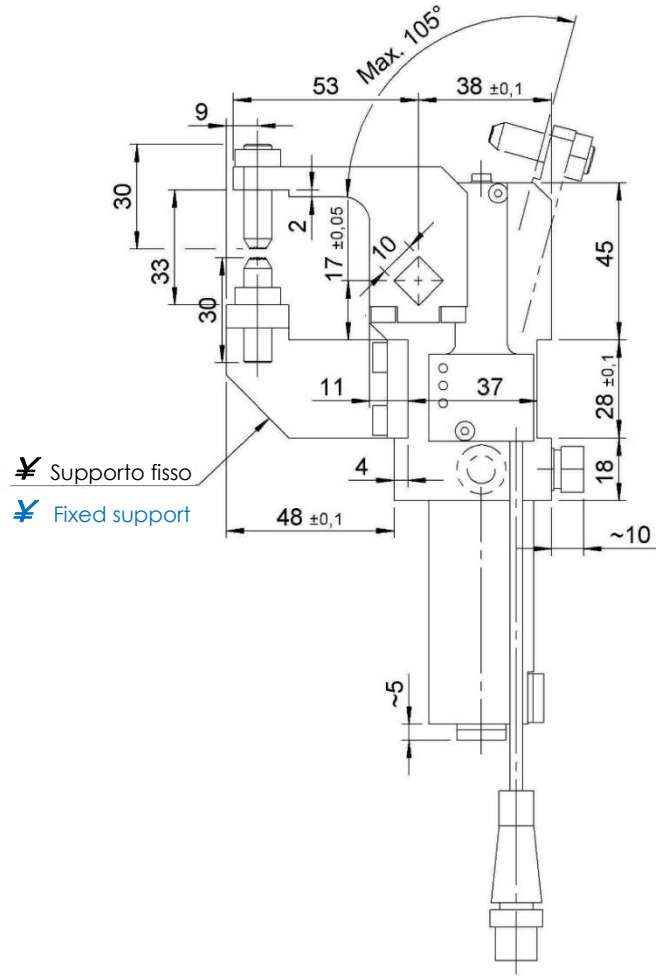
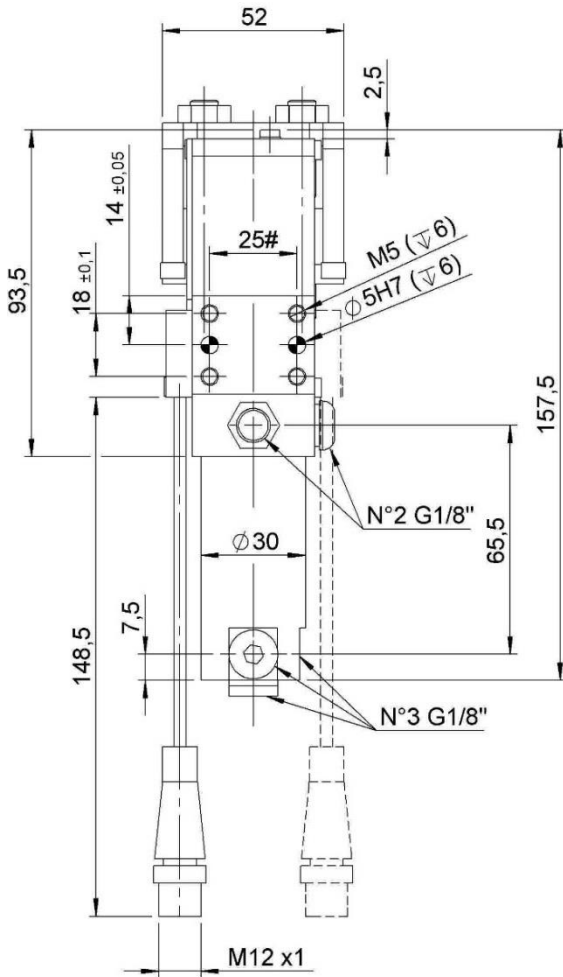

Angolo standard d'apertura = 105°, è possibile settare angoli inferiori ad intervalli di 15°.

Standard opening angle = 105°, it's possible to set a lower angles with steps of 15°.

☞	G2= senza supporto fisso G2/2= con supporto fisso
☞	G2= without fixed support G2/2= with fixed support

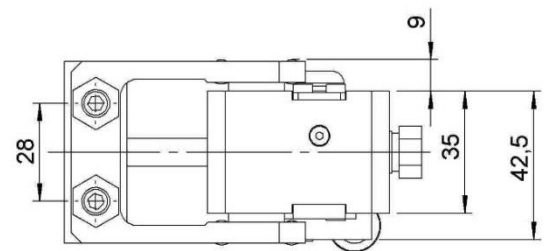

Tolleranze: fori spina: ±0.02 | fori filettati: ±0.1
 #Tolerances: dowel holes: ±0.02 | screw holes: ±0.1

Modello Type	Alesaggio cilindro Cylinder bore	Momento di ritengo Holding moment	Peso Weight	Pressione d'esercizio Working pressure	Coppia max di bloccaggio (5 bar) Clamping max. torque (5 bar)	Consumo d'aria (5 bar) Air consumption (5 bar)
	[mm]	[Nm]	[Kg]	[bar]	[Nm]	[l]
C25-G2...	25	75	~ 1	2 - 8	30	~ 0,2

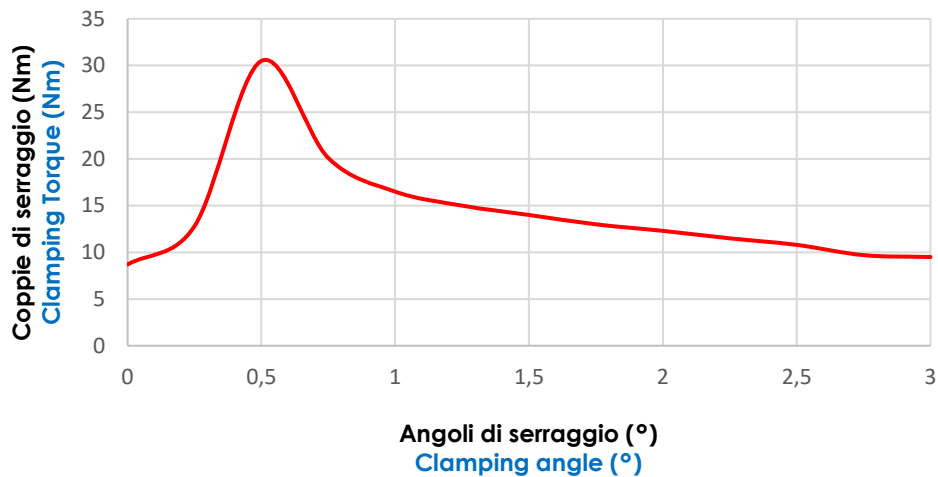
**Diagrammi.****Diagrams.****Coppia di bloccaggio (Nm).****Clamping torque (Nm).**

Coppia max. di bloccaggio (5 bar): **30 Nm**.

Max. clamping torque (5 bar): **30 Nm**.

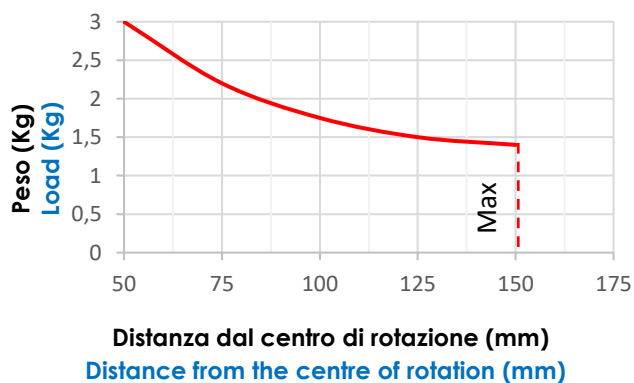
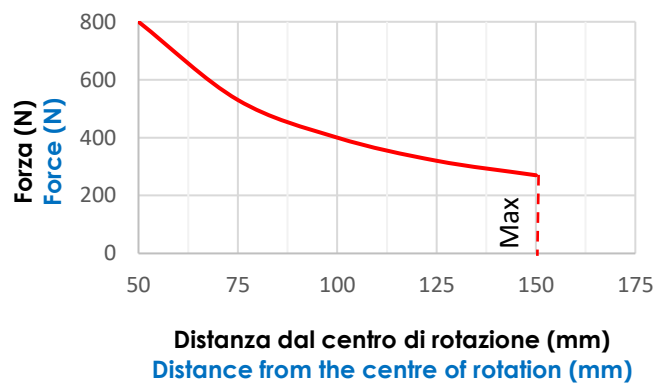
Carico max. applicabile alla leva (Kg).**Max. load applicable on the arm (Kg).****Forza max. esercitata (N).****Max. force applied (N).**

Coppia max. determinata dal peso (5 bar): **1 Nm**.

Max. torque by weight (5 bar): **1 Nm**.



Schema Finecorsa induttivo (cod. 06160/C).

Diagram for Inductive proximity switch (cod. 06160/C).

Caratteristiche tecniche (VEP):

- Tipo di uscita: PNP;
- Tensione d'alimentazione: 10-30 VDC;
- Corrente max. di commutazione: 200 mA;
- Consumo di corrente: < 20 mA;
- Calo di tensione: < 1,8 V
- Campo di temperatura: -25° / 70° C.

Technical data (VEP):

- Output type: PNP;
- Feeding voltage: 10-30 VDC;
- Max. commutating current: 200 mA;
- Power supply: < 20 mA;
- Voltage drop: < 1,8 V;
- Temperature range: -25° / 70° C.

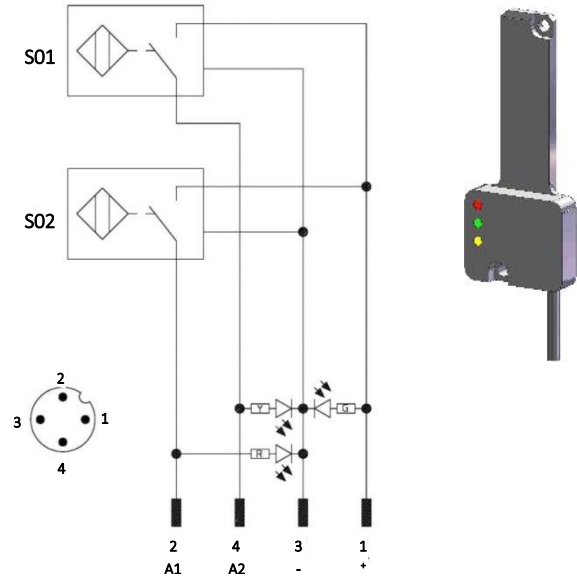

S01 = segnale d'apertura
 S01 = opening signal
 S02 = segnale di chiusura
 S02 = closing signal

Y = LED giallo / yellow LED
 G = LED verde / green LED
 R = LED rosso / red LED

1 = filo marrone / brown wire
 2 = filo nero / black wire
 3 = filo blu / blue wire
 4 = filo bianco / white wire

Schema pneumatico.

Pneumatic plan.

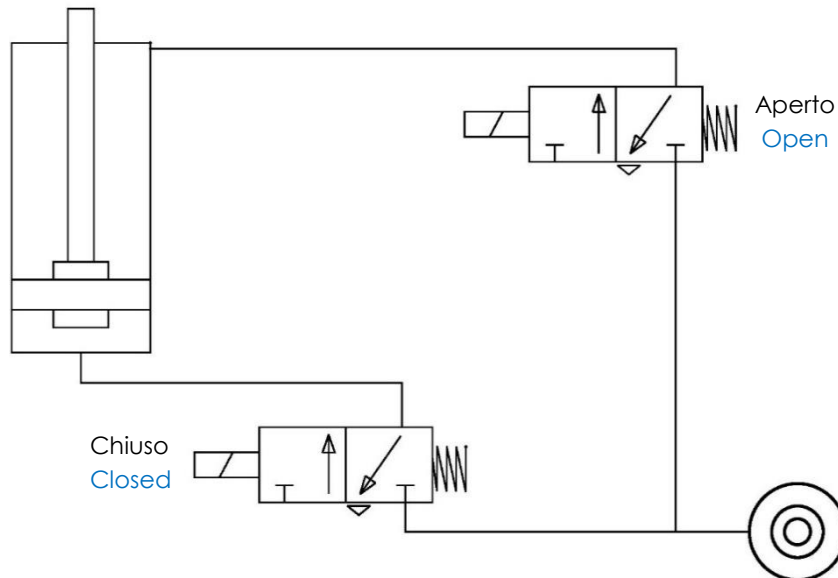

Pressione d'esercizio Working pressure	Consumo d'aria (5 bar) Air consumption (5 bar)
[bar]	[l]
2 - 8	~ 0,2



Istruzioni operative.

Operating instructions.

Modifica angolo d'apertura.

- Togliere il riparo del vano (Det.1) per regolazione angolo o il sensore induttivo, svitando le 2 viti M3 (Det.2), e svitare il perno filettato (Det.3);
- Spostare la leva (Det.4) nella posizione angolare desiderata;
- Riavvitare il perno filettato (coppia di serraggio = 8Nm) nel foro corrispondente all'angolo desiderato e reinserire il riparo all'interno del vano.

Il settaggio del finecorsa induttivo avviene in modo automatico senza effettuare alcuna operazione.

Opening angle change.

- Remove the protection (Det.1) from the angle adjustment compartment or the inductive sensor, unscrewing the 2 screws M3 (Det.2), and unscrew the threaded pin (Det.3);
- Move the clamping arm (Det.4) to the required angular position;
- Tighten the threaded pin (clamping torque = 8Nm) in the hole that corresponding to the desired angle and refit the protection inside the compartment.

The setting of the inductive proximity switch is automatic and doesn't require any operation.

