



## Chiusura pneumatica DL63 - Brevettata

### Pneumatic clamp DL63 - Patented

#### Caratteristiche principali:

- Fianchetti in acciaio
- Dispositivo a ginocchiera
- Perno di controllo della posizione finale
- Tassello fermo leva esterno
- Leve versatili in acciaio
- 4 possibilità di staffaggio (fronte, retro e laterali)
- Alesaggio del cilindro pneumatico: 63 mm
- 3 fori di connessione G1/4"
- Finecorsa induttivo P+F (connessione M12x1)
- Comando manuale

#### Main characteristics:

- Steel flanks
- Toggle action mechanism
- Checking pin for verifying the end position
- External arm hard stop
- Versatile steel arms 4 mounting areas (front, back, and on the sides)
- Pneumatic cylinder bore: 63 mm
- 3 feeding ports G1/4"
- Inductive proximity switch P+F (connection M12x1)
- Hand lever



[PDF](#)



[3D Step](#)



[WEB](#)

#### Indice.

#### Index.

Pagina Page	Descrizione Description	
1	Caratteristiche principali <a href="#">Main characteristics</a>	
2	Codice d'ordine <a href="#">Ordering example</a>	
3	Pagina dimensionale <a href="#">Dimensional page</a>	
4		DL63-A1C
5		DL63-A2C
6		DL63-B1C
7		DL63-B2C
8		DLM63-A1C
9		DLM63-A2C
10		DLM63-B1C
11	Diagrammi <a href="#">Diagrams</a>	
12	Schema finecorsa induttivo / Schema pneumatico <a href="#">Diagram for inductive proximity switch / Pneumatic plan</a>	
13	Ricambi / <a href="#">Spare parts</a>	
14	Note / <a href="#">Notes</a>	



## Codice d'ordine. Ordering example.

**DL63 – LD – A1C – I – 75**

**Modello ed alesaggio cilindro:**  
**Model and cylinder bore:**

**DL63**  
chiusura standard DL  
standard clamp DL

**DLM63**  
chiusura standard DL  
con comando manuale  
standard clamp DL  
with manual control position

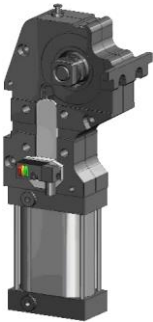

**Finecorsa:**  
**Proximity switch:**

**X:** senza finecorsa  
without proximity switch

**I:** induttivo  
inductive



**Angolo d'apertura non regolabile:**  
**Non adjustable opening angle:**

A1	45°	60°	75°	90°
B1	45°	60°	75°	90°
A2	45°	60°	70°	---
B2	45°	60°	70°	---

**Posizione comando manuale:**  
**Hand lever position:**

**LD:** leva destra  
right level

**LS:** leva sinistra  
left level



**Tipologia leva:**  
**Type of arm:**

**XXX:** senza leva  
without arm

**A1C:** leve A1 centrali (vedere pag. 3)  
arm A1 central (see page 3)

**A2C:** leve A2 centrali (vedere pag. 4)  
arm A2 central (see page 4)

**B1C:** leve B1 centrali (vedere pag. 5)  
arm B1 central (see page 5)

**B2C:** leve B2 centrali (vedere pag. 6)  
arm B2 central (see page 6)

N.B.: è possibile trasformare la chiusura tipo A1/2C nel tipo B1/2C semplicemente cambiando la posizione della leva.  
NOTE: It's possible to transform the clamp type A1/2C into the type B1/2C simply changing the arm position.

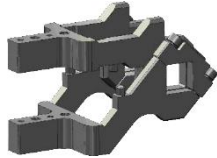



## DL63-A1C...

Chiusura, D.63, Doppia Leva, Verticale, Offset 15 (A1)  
Clamp, D.63, Double Arm, Vertical, Offset 15 (A1)

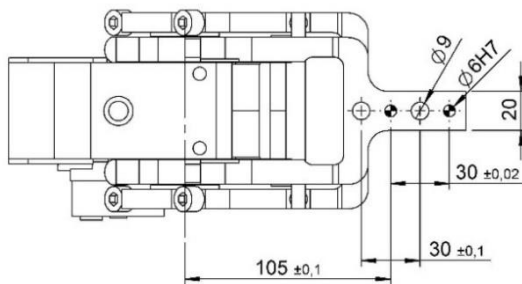
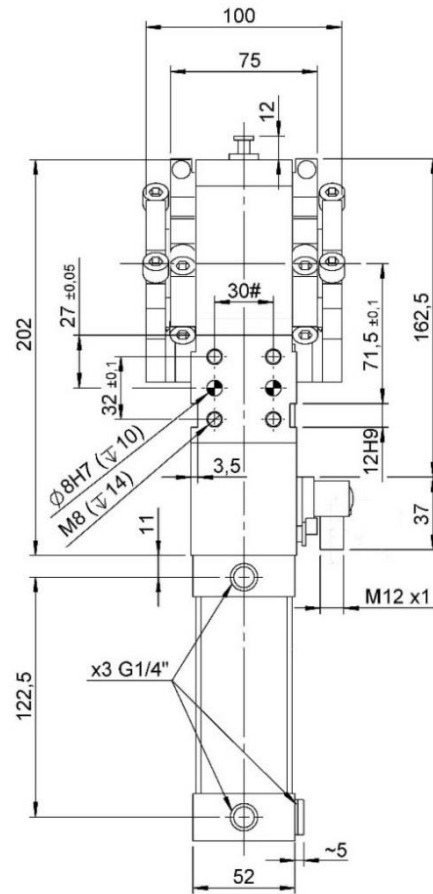
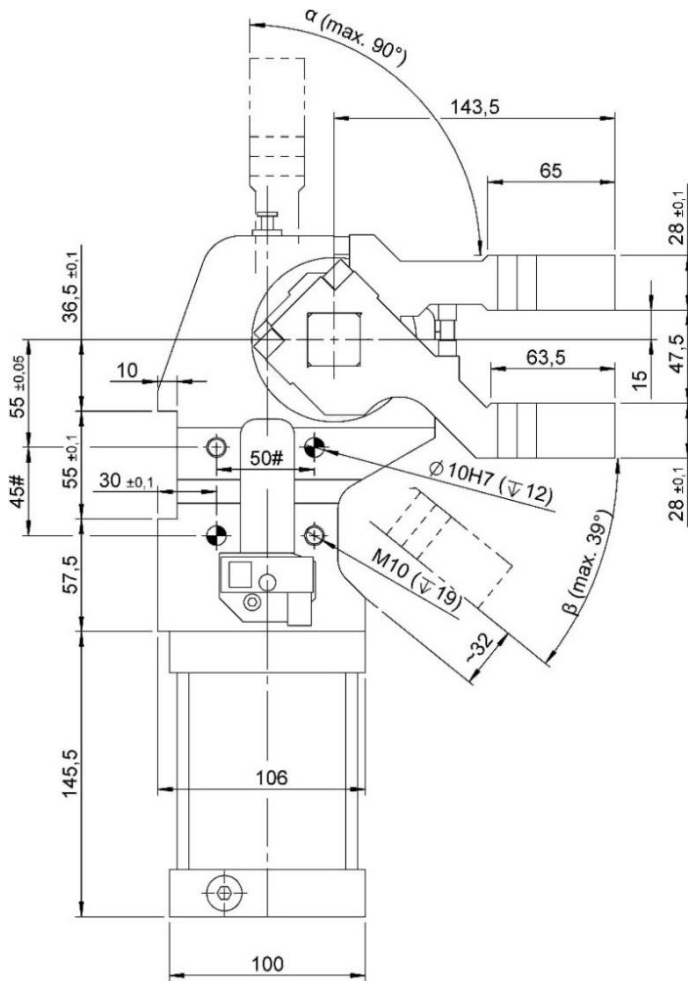

È possibile trasformare la chiusura tipo A1/2C nel tipo B1/2C semplicemente cambiando la posizione della leva.

It's possible to transform the clamp type A1/2C into the type B1/2C simply changing the arm position.

#Tolleranze: fori spina ±0.02, fori filettati ±0.1

#Tolerances: dowel holes ±0.02, screw holes ±0.1

Modello Type	Angolo d'apertura (α) Opening angle (α)	Angolo d'apertura (β) Opening angle (β)	Alesaggio cilindro Cylinder bore	Momento di ritegno Holding moment	Peso Weight	Pressione d'esercizio Working pressure	Coppia max di bloccaggio (5 bar) Clamping max. torque (5 bar)	Consumo d'aria (5 bar) Air consumption (5 bar)
	[ ° ]	[ ° ]						
DL63-A1C	45°	7°	63	600	~ 10,0	2 - 8	400	~ 2,6
DL63-A1C	60°	16°						
DL63-A1C	75°	27°						
DL63-A1C	90°	39°						





## DL63-B1C...

Chiusura, D.63, Doppia Leva, Orizz. Simm. + Vert., Offset 15 (B1C)  
 Clamp, D.63, Double Arm, Horiz. Symm. + Vert., Offset 15 (B1C)

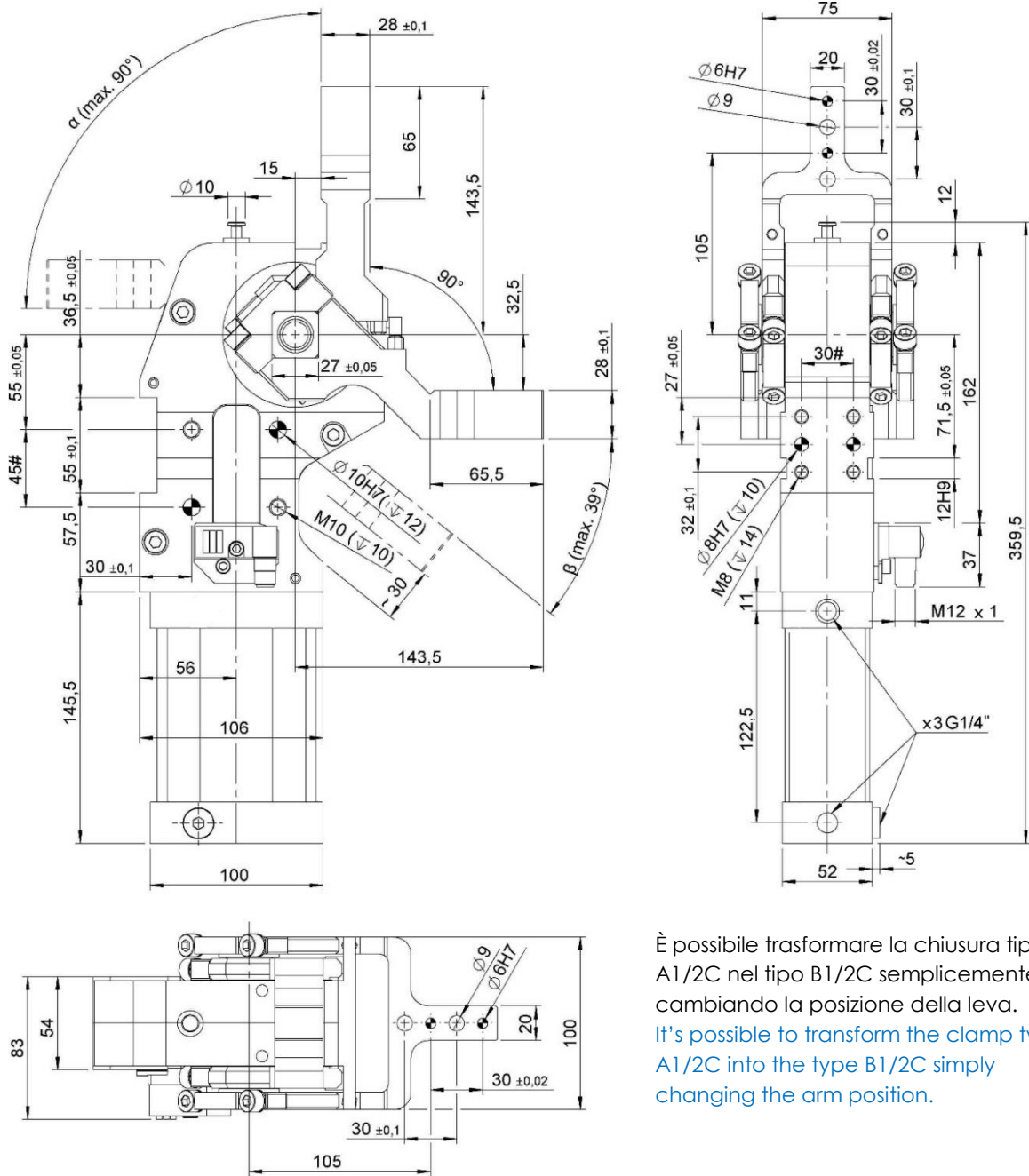

È possibile trasformare la chiusura tipo A1/2C nel tipo B1/2C semplicemente cambiando la posizione della leva.  
 It's possible to transform the clamp type A1/2C into the type B1/2C simply changing the arm position.

#Tolleranze: fori spina ±0.02, fori filettati ±0.1  
 #Tolerances: dowel holes ±0.02, screw holes ±0.1

Modello Type	Angolo d'apertura (α) Opening angle (α)	Angolo d'apertura (β) Opening angle (β)	Alesaggio cilindro Cylinder bore	Momento di ritegno Holding moment	Peso Weight	Pressione d'esercizio Working pressure	Coppia max di bloccaggio (5 bar) Clamping max. torque (5 bar)	Consumo d'aria (5 bar) Air consumption (5 bar)
	[ ° ]	[ ° ]	[ mm ]	[ Nm ]	[ Kg ]	[ bar ]	[ Nm ]	[ l ]
DL63-B1C	45°	7°	63	600	~ 10,0	2-8	400	~ 2,6
DL63-B1C	60°	16°						
DL63-B1C	75°	27°						
DL63-B1C	90°	39°						



## DL63-B2C...

Chiusura, D.63, Doppia Leva, Orizz. + Vert., Offset 15 (B2C)  
 Clamp, D.63, Double Arm, Horiz. + Vert., Offset 15 (B2C)

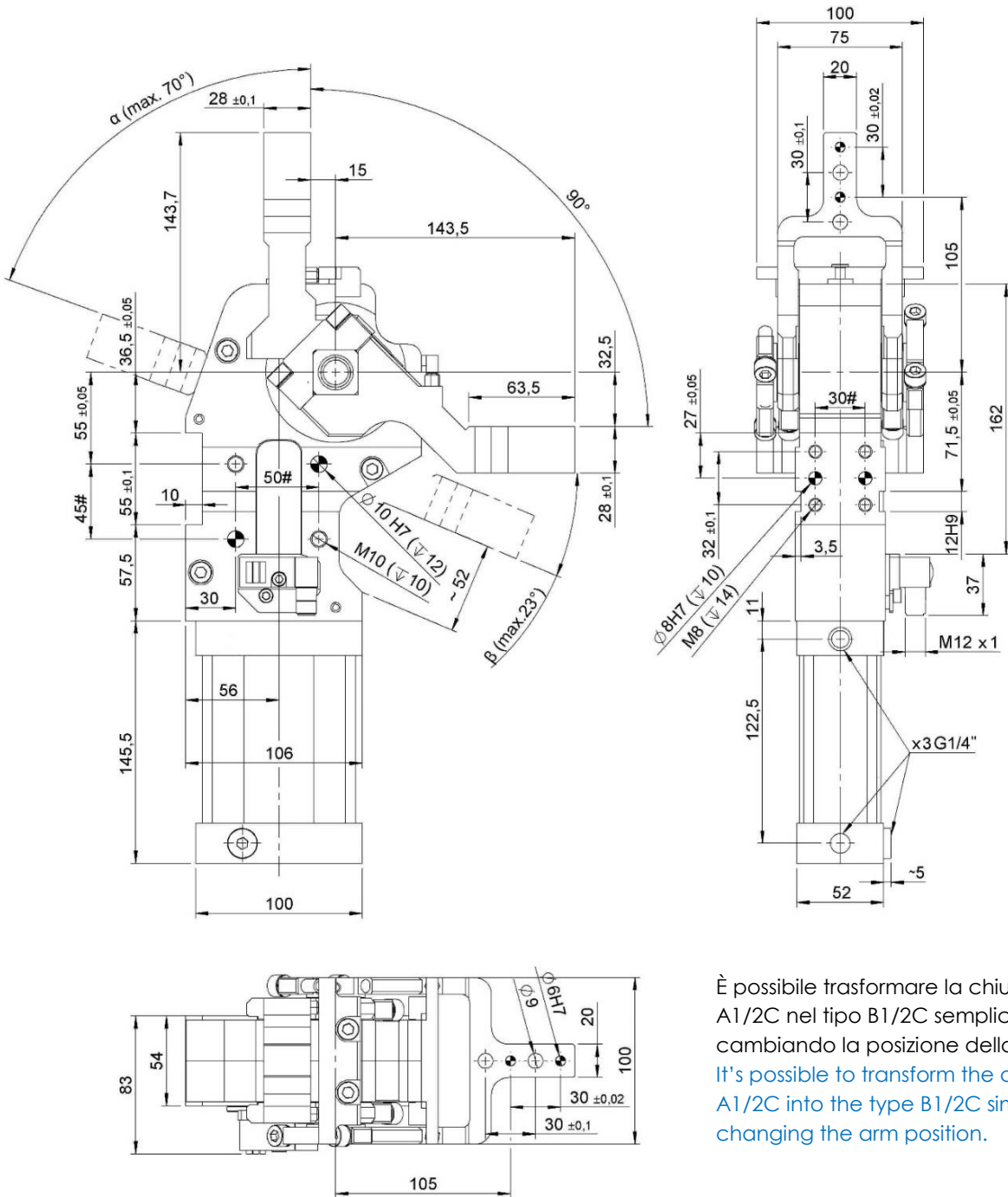

È possibile trasformare la chiusura tipo A1/2C nel tipo B1/2C semplicemente cambiando la posizione della leva.  
 It's possible to transform the clamp type A1/2C into the type B1/2C simply changing the arm position.

#Tolleranze: fori spina  $\pm 0.02$ , fori filettati  $\pm 0.1$   
 #Tolerances: dowel holes  $\pm 0.02$ , screw holes  $\pm 0.1$

Modello Type	Angolo d'apertura ( $\alpha$ ) Opening angle ( $\alpha$ )	Angolo d'apertura ( $\beta$ ) Opening angle ( $\beta$ )	Alesaggio cilindro Cylinder bore	Momento di ritegno Holding moment	Peso Weight	Pressione d'esercizio Working pressure	Coppia max di bloccaggio (5 bar) Clamping max. torque (5 bar)	Consumo d'aria (5 bar) Air consumption (5 bar)
	[ ° ]	[ ° ]	[ mm ]	[ Nm ]	[ Kg ]	[ bar ]	[ Nm ]	[ l ]
DL63-B2C	45°	7°	63	600	~ 10,0	2 – 8	400	~ 2,6
DL63-B2C	60°	16°						
DL63-B2C	70°	23°						



## DLM-A1C...

Chiusura, D.63, Doppia Leva, Cmd. Manuale, Vert., Offset 15 (A1C)  
 Clamp, D.63, Double Arm, Hand Lever, Vert., Offset 15 (A1C)

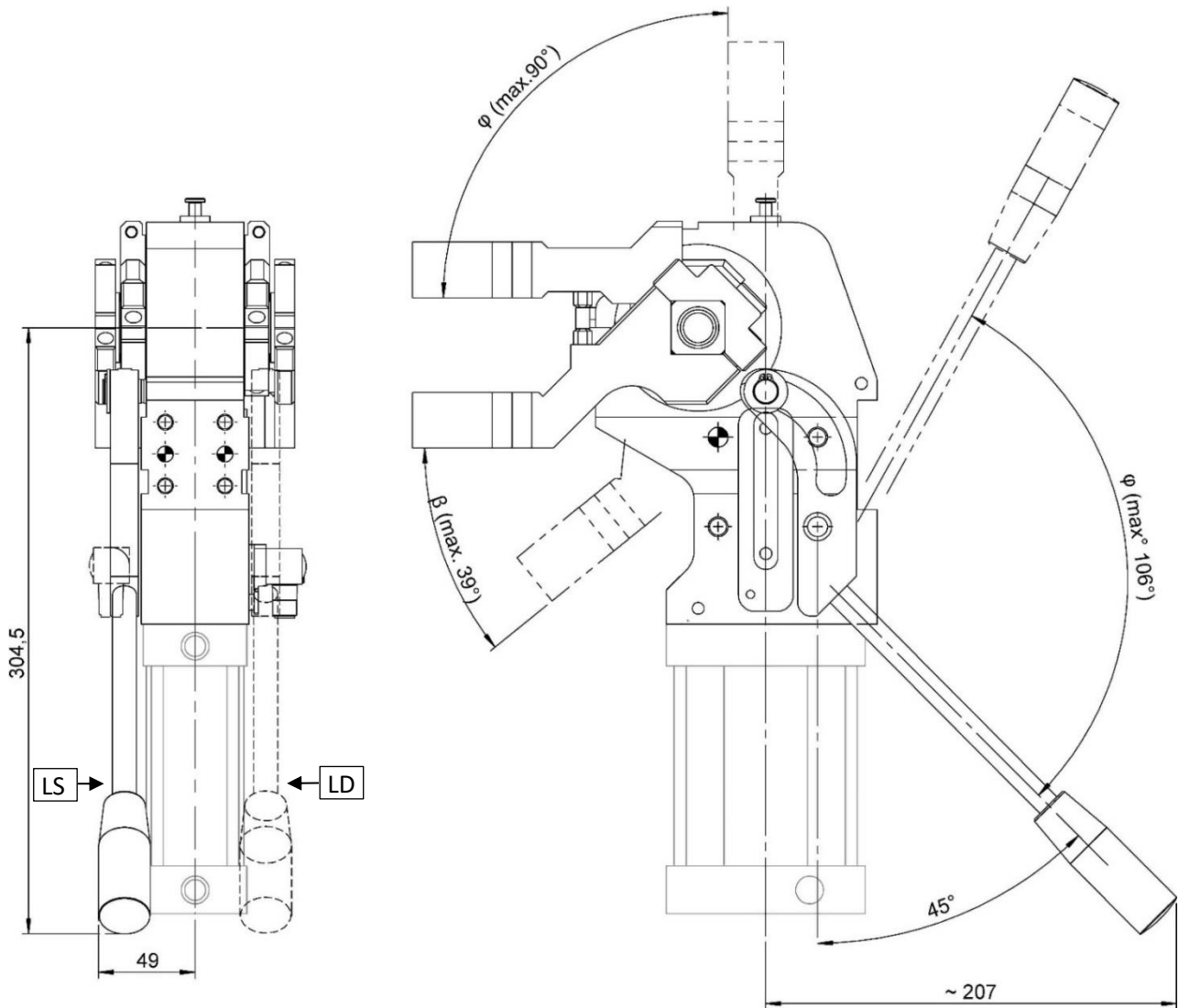

$\alpha$	45°	60°	75°	90°
$\beta$	7°	16°	27°	39°
$\varphi$	56°	70°	87°	106°

Modello Type	Alesaggio cilindro Cylinder bore	Momento di ritegno Holding moment	Peso Weight	Pressione d'esercizio Working pressure	Consumo d'aria (5 bar) Air consumption (5 bar)	Max. forza manuale applicabile Max. manual force
	[ mm ]	[ Nm ]	[ Kg ]	[ bar ]	[ l ]	[ N ]
DLM-A1C	63	600	~ 10,5	2 - 8	2,6	150



## DLM-A2C...

Chiusura, D.63, Doppia Leva, Cmd. Manuale, Orizz., Offset 15 (A2C)  
 Clamp, D.63, Double Arm, Hand Lever, Horiz., Offset 15 (A2C)

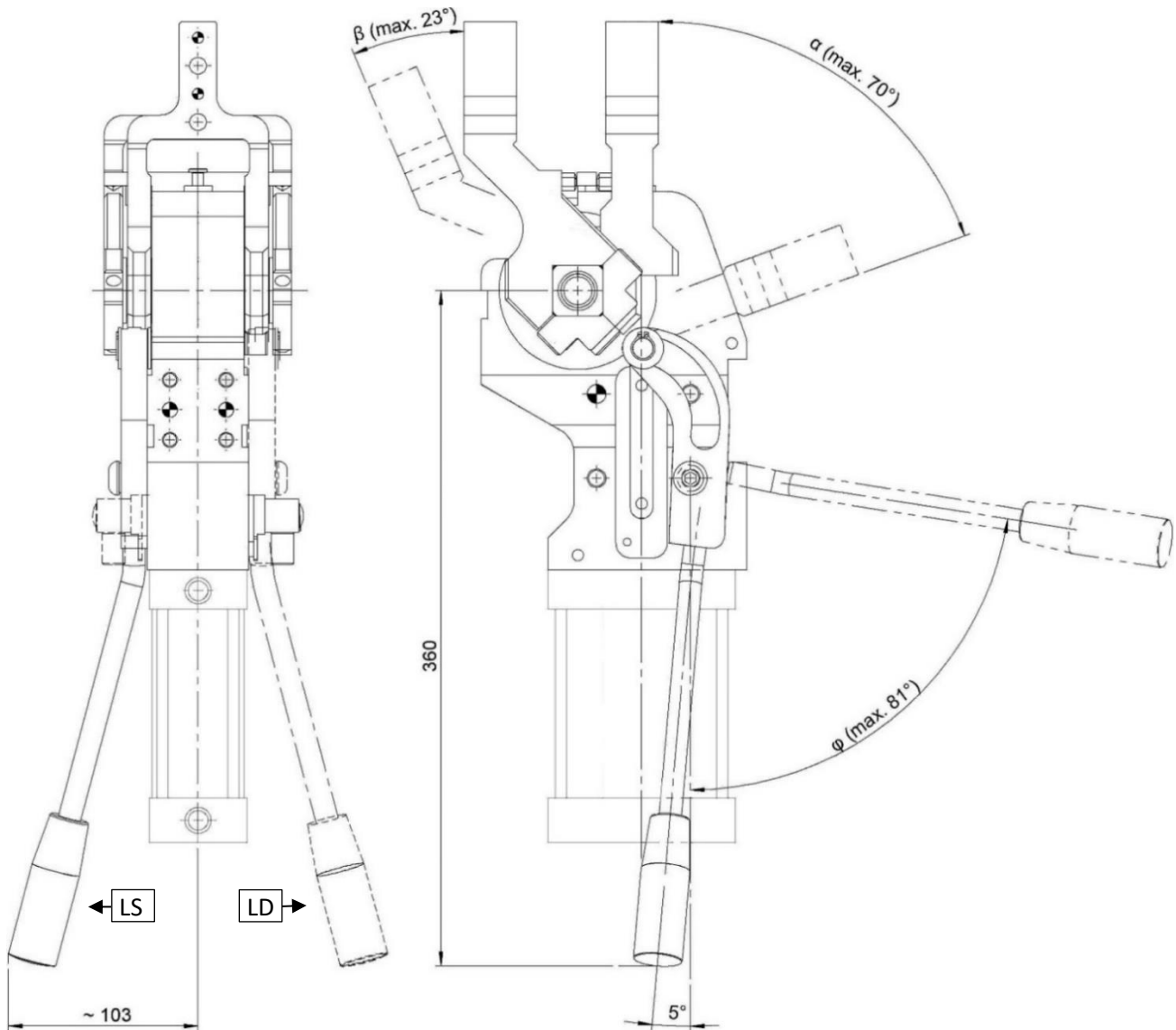

$\alpha$	45°	60°	70°
$\beta$	7°	16°	23°
$\varphi$	56°	70	81°

Modello Type	Alesaggio cilindro Cylinder bore	Momento di ritegno Holding moment	Peso Weight	Pressione d'esercizio Working pressure	Consumo d'aria (5bar) Air consumption (5 bar)	Max. forza manuale applicabile Max. manual force
	[ mm ]	[ Nm ]	[ Kg ]	[ bar ]	[ l ]	[ N ]
DLM-A2C	63	600	~ 10,5	2 - 8	2,6	150



## DLM-B1C...

Chiusura, D.63, Doppia Leva, Cmd. Manuale, Orizz. Sim.+Vert., Offset15 (B1C)  
 Clamp, D.63, Double Arm, Hand Lever, Horiz. Sym.+Vert., Offset 15 (B1C)

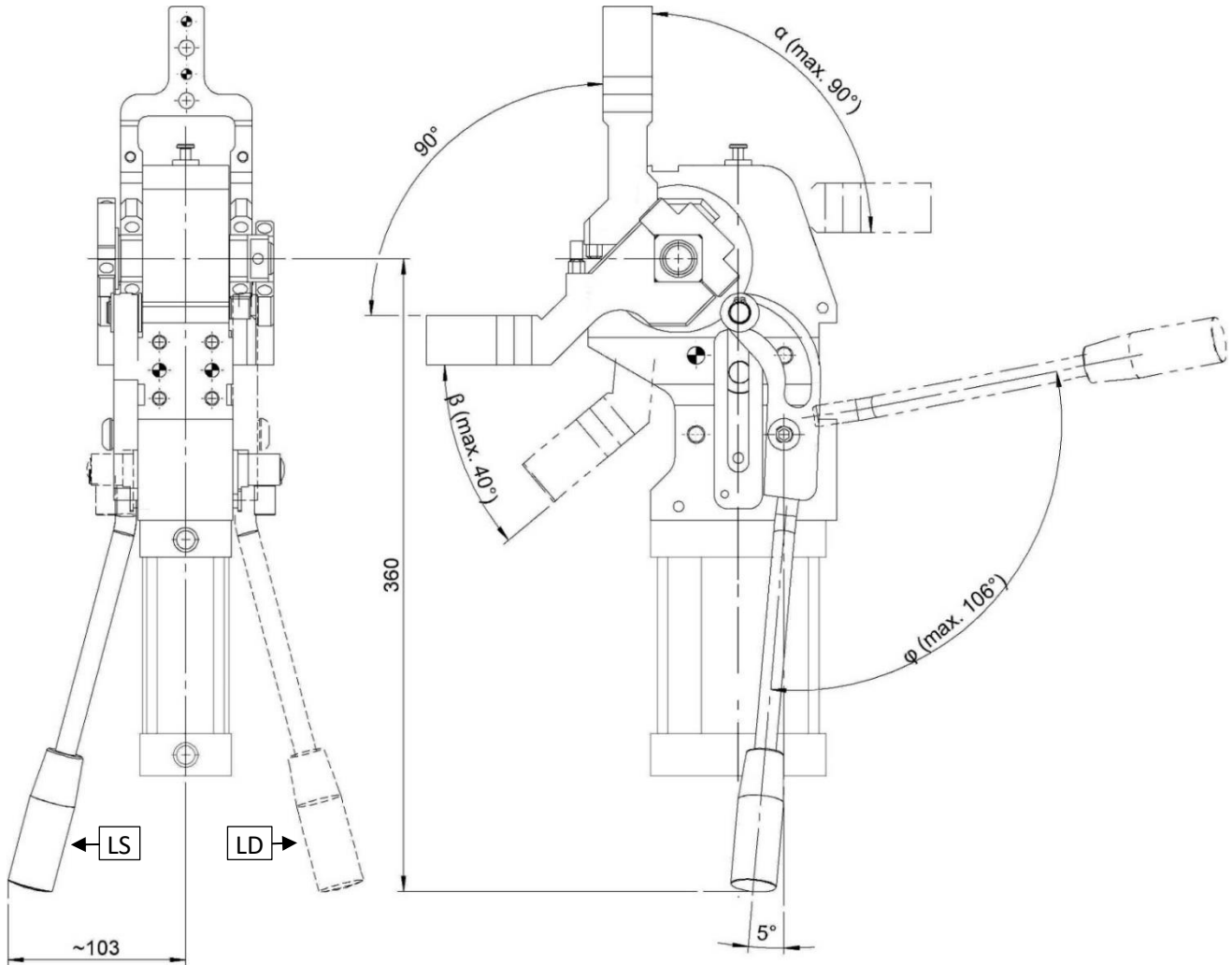

$\alpha$	45°	60°	75°	90°
$\beta$	7°	16°	27°	39°
$\varphi$	56°	70	87°	106°

Modello Type	Alesaggio cilindro Cylinder bore	Momento di ritegno Holding moment	Peso Weight	Pressione d'esercizio Working pressure	Consumo d'aria (5 bar) Air Consumption (5 bar)	Max. forza manuale applicabile Max. manual force
	[ mm ]	[ Nm ]	[ Kg ]	[ bar ]	[ l ]	[ N ]
DLM-B1C	63	600	~ 10,5	2 - 8	2,6	150



## DLM-B2C...

Chiusura, D.63, Doppia Leva, Cmd. Manuale, Oriz+Vert, Offset15 (B2C)  
 Clamp, D.63, Double Arm, Hand Lever, Horiz. + Vert., Offset 15 (B2C)

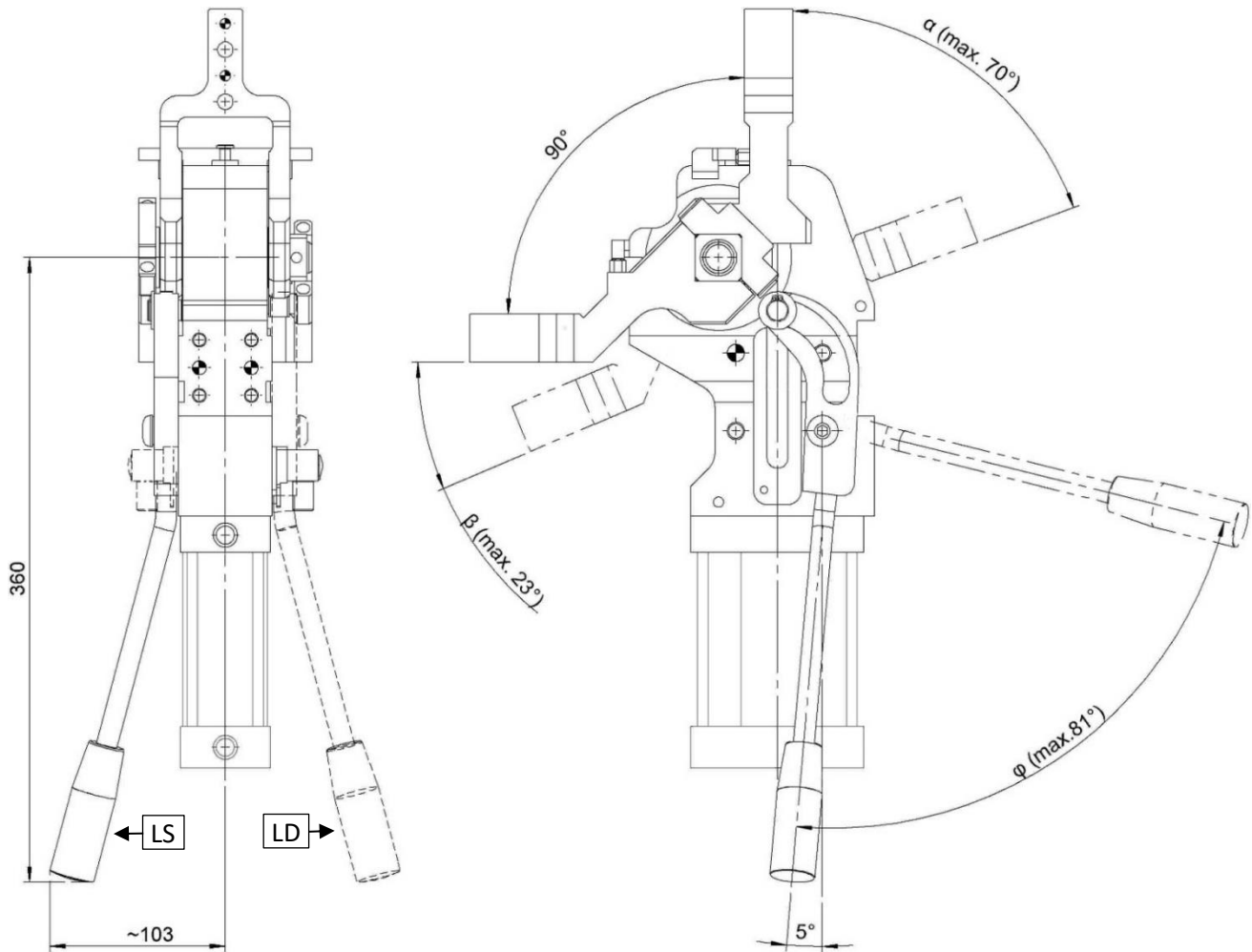

$\alpha$	45°	60°	70°
$\beta$	7°	16°	23°
$\varphi$	56°	70	81°

Modello Type	Alesaggio cilindro Cylinder bore	Momento di ritegno Holding moment	Peso Weight	Pressione d'esercizio Working pressure	Consumo d'aria (5 bar) Air consumption (5 bar)	Max. forza manuale applicabile Max. manual force
	[ mm ]	[ Nm ]	[ Kg ]	[ bar ]	[ l ]	[ N ]
DLM-B2C	63	600	~ 10,5	2 - 8	2,6	150

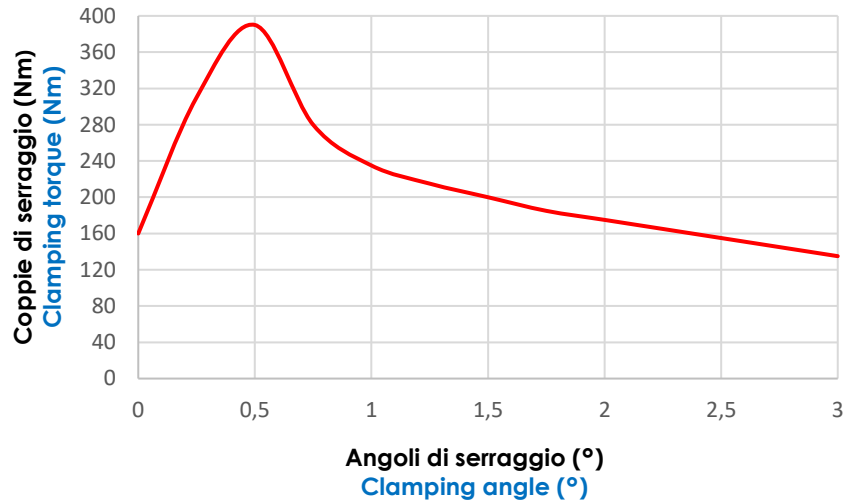
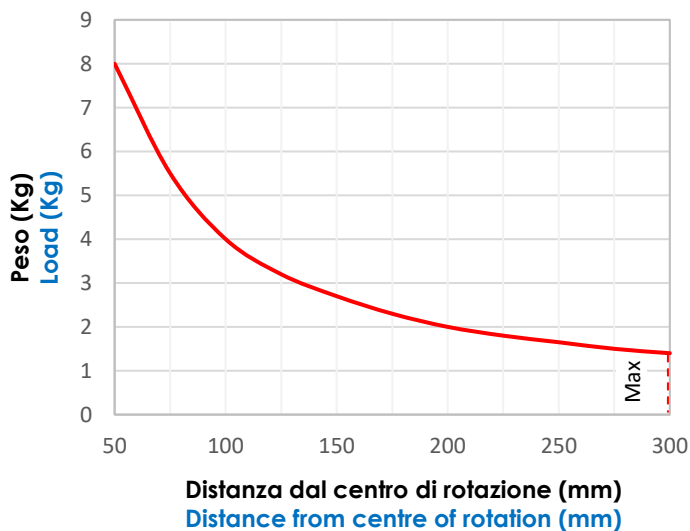
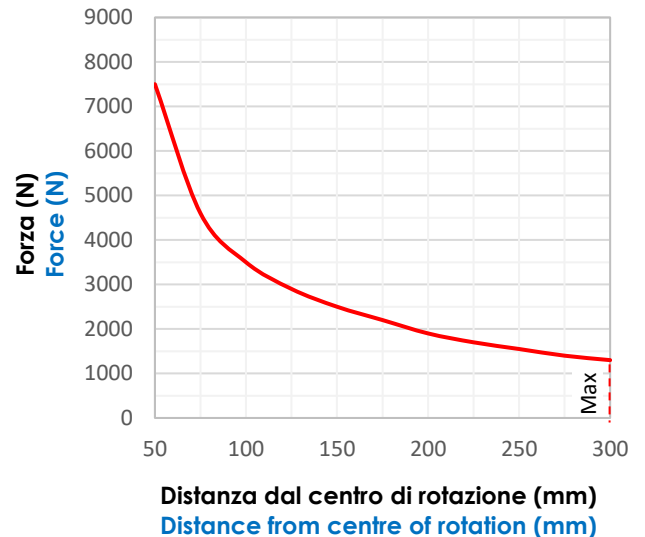
**Diagrammi.****Diagrams.****Coppia di bloccaggio (Nm).****Clamping torque (Nm).****Coppia max. di bloccaggio (5 bar): 400 Nm.****Max. clamping torque (5 bar): 400 Nm.****Carico max. applicabile alla leva (Kg).****Max. load applicable on the arm (Kg).****Forza max. esercitata (N).****Max. force applied (N).****Coppia max. determinata dal peso (5 bar): 4Nm.****Max. torque by weight (5 bar): 4Nm.**La coppia di carico massima per le applicazioni con il tassello fuori asse è pari a **3 Nm**.The maximal load by torque for the applications with block out of axis is **3 Nm**.



## Schema Finecorsa induttivo (cod. 05830/B/C).

### Diagram for Inductive proximity switch (cod. 05830/B/C).

Caratteristiche tecniche (P+F):

- Tipo di uscita: PNP;
- Tensione d'alimentazione: 10-30 VDC;
- Corrente max. di commutazione: 200 mA;
- Consumo di corrente: < 20 mA;
- Calo di tensione: < 1,8 V
- Campo di temperatura: -25° / 70° C.

#### Technical data (P+F):

- Output type: PNP;
- Feeding voltage: 10-30 VDC;
- Max. commutating current: 200 mA;
- Power supply: < 20 mA;
- Voltage drop: < 1,8 V;
- Temperature range: -25° / 70° C.

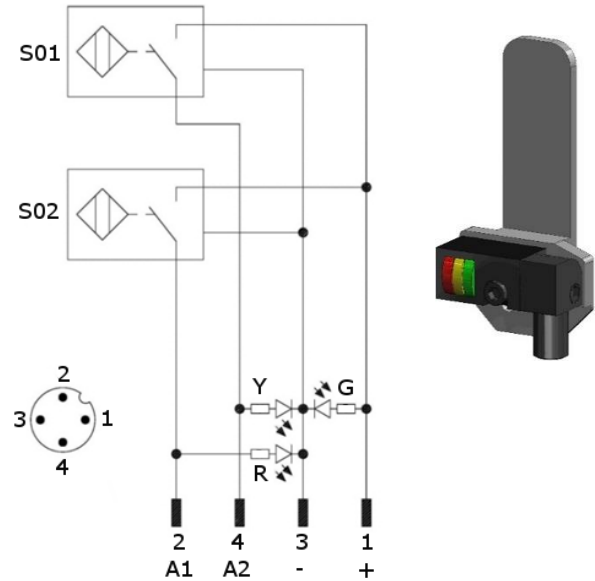

S01 = segnale d'apertura  
 S01 = opening signal  
 S02 = segnale di chiusura  
 S02 = closing signal

Y = LED giallo / yellow LED  
 G = LED verde / green LED  
 R = LED rosso / red LED

1 = filo marrone / brown wire  
 2 = filo nero / black wire  
 3 = filo blu / blue wire  
 4 = filo bianco / white wire

## Schema pneumatico.

### Pneumatic plan.

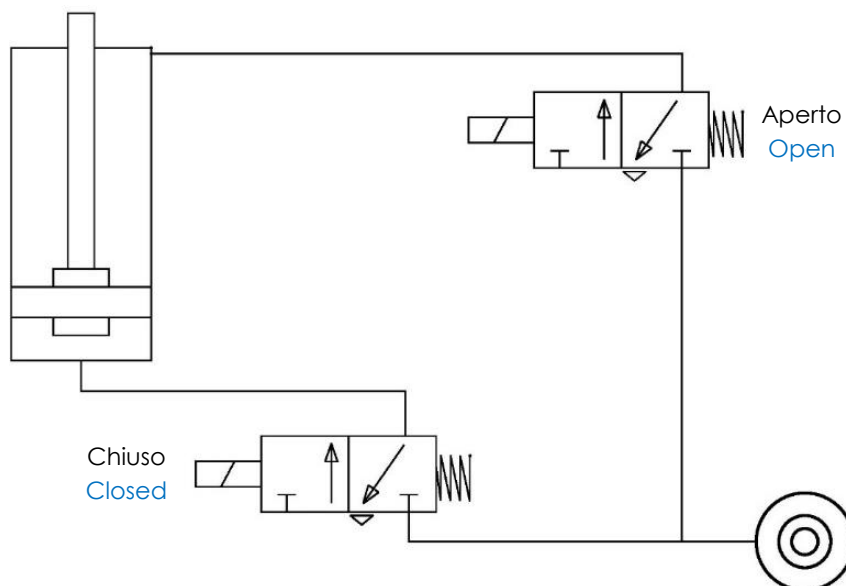

Pressione d'esercizio  
 Working pressure

[ bar ]

2 – 8