



Chiusura manuale MC Hand clamp MC

Caratteristiche principali:

- Design compatto
- Corpo in acciaio
- Dispositivo a ginocchiera
- Tassello fermo leva esterno
- Leve in acciaio versatili V1, V2 V3 e O1, O2, O3
- Staffaggio sul lato frontale
- Dispositivo di limitazione apertura

Main characteristics:

- Compact design
- Steel body
- Toggle action mechanism
- External arm hard stop
- Versatile steel arms V1, V2, V3 and O1, O2, O3
- Front mounting area
- Opening locking device

[PDF](#)[3D Step](#)[WEB](#)

Indice.

Index.

Pagina Page	Descrizione Description	
1	Caratteristiche principali Main characteristics	
2	Codice d'ordine Ordering example	
3	Pagina dimensionale Dimensional page	MC-V...120 X
4		MC-O...120 X
5	Accessori Accessories	Dispositivo di limitazione apertura Opening loking device
6	Ricambi / Spare parts	
7	Note / Notes	



Codice d'ordine.
Ordering example.

MC	-	V1C	-	120	-	XX				
<p>Modello: Model:</p> <p>MC chiusura manuale MC hand clamp MC</p> 				<p>Angolo d'apertura: Opening angle:</p> <table border="1" style="margin-left: auto; margin-right: auto;"> <tr> <td style="padding: 2px 10px;">60°</td> <td style="padding: 2px 10px;">90°</td> <td style="padding: 2px 10px;">120°</td> </tr> </table>	60°	90°	120°			
60°	90°	120°								
						<p>Dispositivo di limitazione apertura: Opening locking device:</p>  <p>XX: senza without</p> <p>LD: con dispositivo di limitazione sul lato destro with locking device on right side</p> <p>LS: con dispositivo di limitazione sul lato sinistro with locking device on left side</p> <p><u>N.B. tale dispositivo è obbligatorio con angoli diversi da 120°</u> <u>Note: this device is obligatory with angles different to 120°</u></p>				
		<p>Tipologia leva: Type of arm:</p>  <p>XXX: senza leva without arm</p> <p>V1C: (h 15mm) (h15mm)</p> <p>V2C: (h 25mm) (h25mm)</p> <p>V3C: (h 45mm) (h45mm)</p> <p>O1C: (h 15mm) (h15mm)</p> <p>O2C: (h 25mm) (h 25mm)</p> <p>O3C: (h 45mm) (h 45mm)</p> <p style="margin-left: 20px;">(vedere pag. 3) (see page 3)</p> <p style="margin-left: 20px;">(vedere pag. 4) (see page 4)</p> <p><u>N.B.: è possibile trasformare la chiusura tipo V nel tipo O semplicemente cambiando la posizione della leva.</u> <u>NOTE: It's possible to transform the clamp type V into the type O simply changing the arm position.</u></p>								



MC-V...

Chiusura Manuale, Leva Verticale Offset 15/25/45
Manual Clamp, Vertical Arm Offset 15/25/45

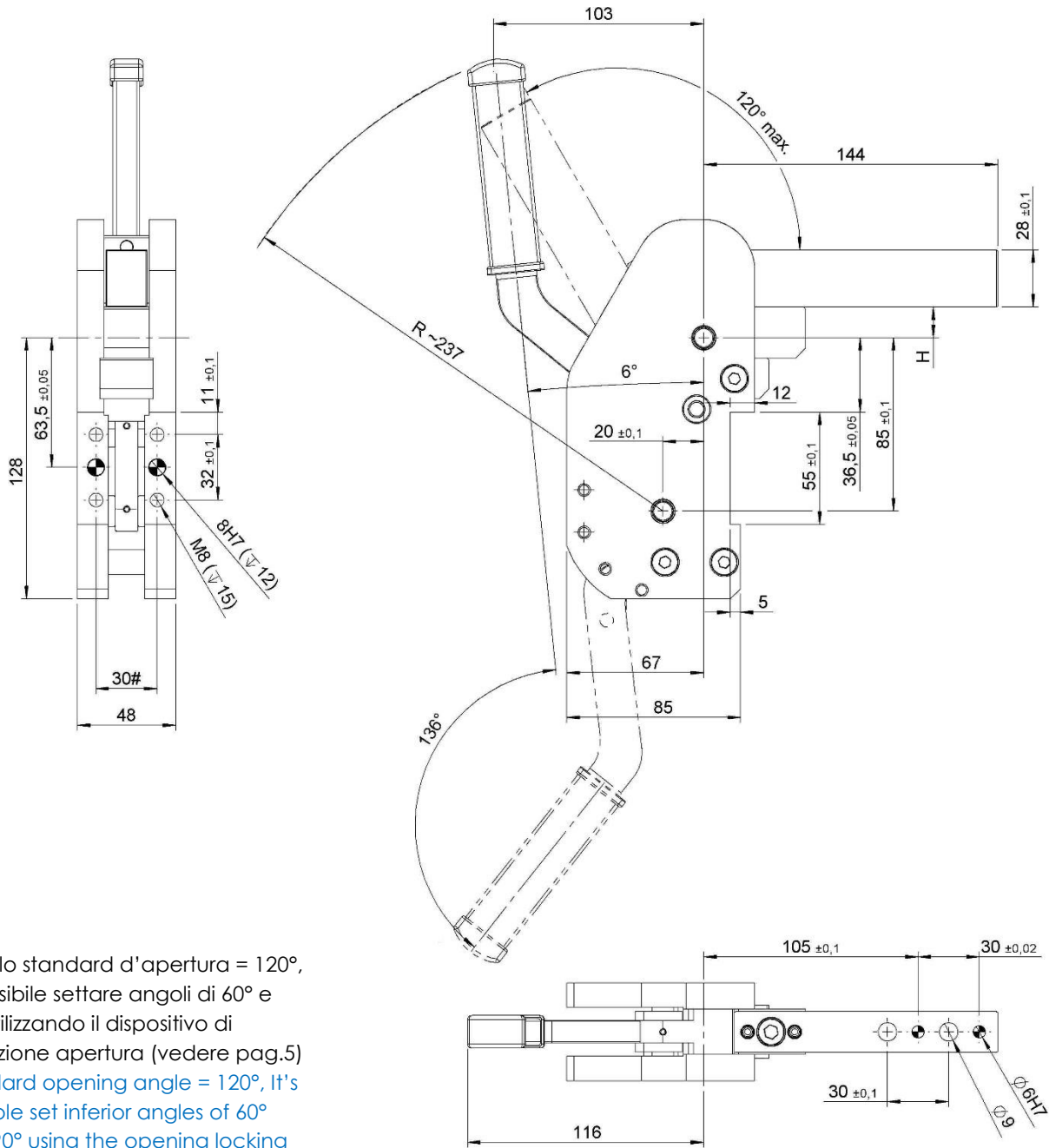

Angolo standard d'apertura = 120°,
è possibile settare angoli di 60° e
90° utilizzando il dispositivo di
limitazione apertura (vedere pag.5)
Standard opening angle = 120°, It's
possible set inferior angles of 60°
and 90° using the opening locking
device (see page 5).

#Tolleranze: fori spina ±0.02, fori filettati ±0.1
#Tolerances: dowel holes ±0.02, screw holes ±0.1

Modello Type	H	Peso Weight	Momento di ritegno Holding moment
	[mm]		
MC-V1C...	15	4,3	160
MC-V2C...	25		
MC-V3C...	45		



MC-O...

Chiusura Manuale, Leva Orizzontale Offset 15/25/45
Manual Clamp, Horizontal Arm Offset 15/25/45

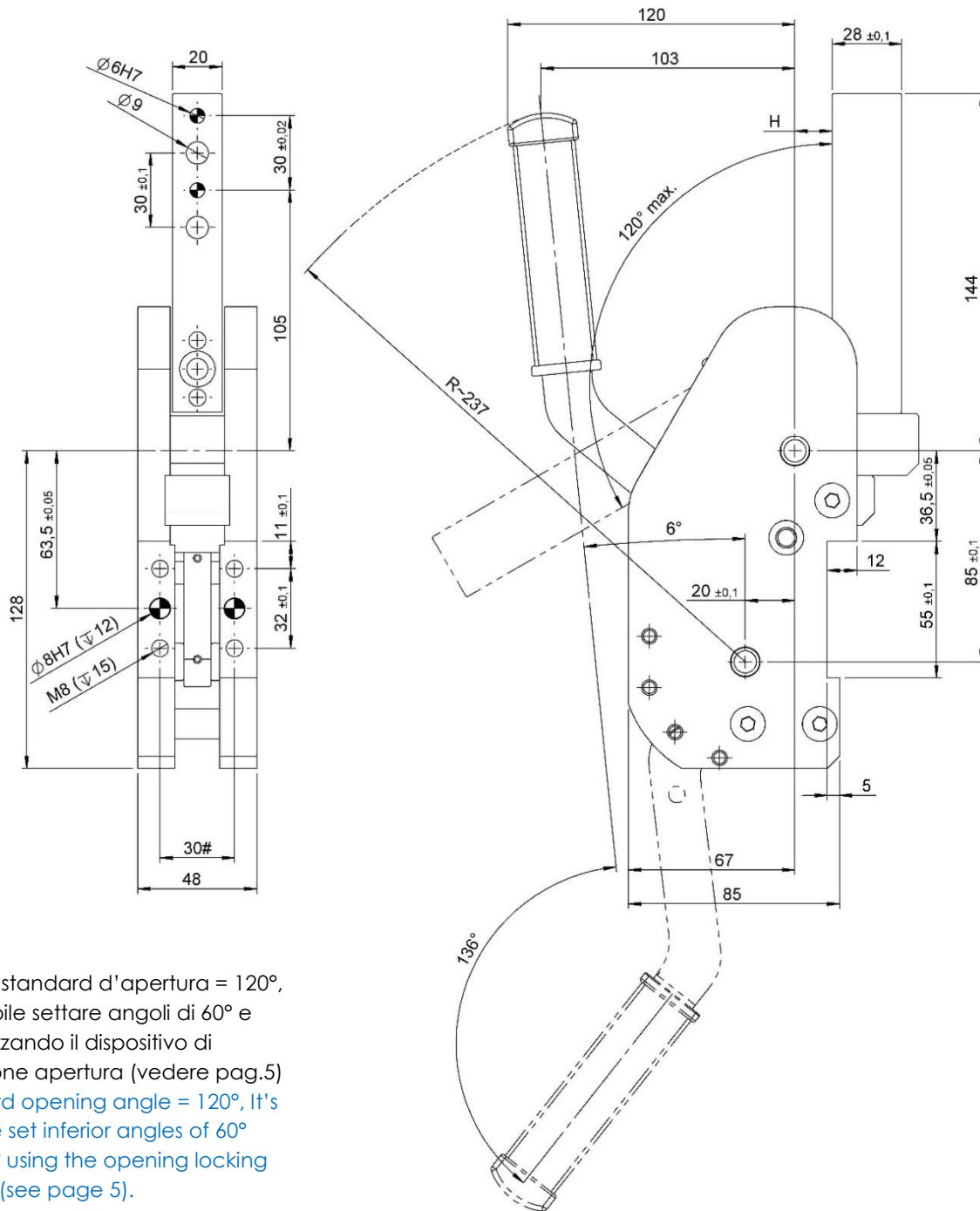

Angolo standard d'apertura = 120°,
è possibile settare angoli di 60° e
90° utilizzando il dispositivo di
limitazione apertura (vedere pag.5)
Standard opening angle = 120°. It's
possible set inferior angles of 60°
and 90° using the opening locking
device (see page 5).

#Tolleranze: fori spina ±0.02, fori filettati ±0.1
#Tolerances: dowel holes ±0.02, screw holes ±0.1

Modello Type	H	Peso Weight	Momento di ritegno Holding moment
	[mm]	[Kg]	[Nm]
MC-O1C...	15	4,3	160
MC-O2C...	25		
MC-O3C...	45		



Accessori.

Accessories.

Dispositivo di limitazione apertura (codice 06625/C).

Questo dispositivo applicato sul fianco (destra o sinistra) della chiusura serve a limitare l'angolo max. d'apertura. (Angolo max. d'apertura: 120°, angoli max. ottenibili: 60° e 90°).

Opening locking device (code 06625/C).

This device applied on the side (right or left) of the clamp limit the max. opening angle. (Max. opening angle: 120°, max. available opening angle: 60° and 90°).

